

DG Flugzeugbau GmbH

Otto-Lilienthal-Weg 2 / Am Flugplatz • D-76646 Bruchsal • Germany

Postbox 1480, D-76604 Bruchsal • Germany

Tel. 07251/3020-100 • Telefax 07251/3020-200 • eMail: dg@dg-flugzeugbau.de

Spare part and material sales: Tel. 07251/3020-270 • lager@dg-flugzeugbau.de

www.dg-flugzeugbau.de

FLIGHTMANUAL

FOR THE

SAILPLANE

DG-1000S

Type: DG-1000
Variant: DG-1000S
Data Sheet No.: LBA 413, EASA.A.072

Factory Serial No.: _____

Registration No.: _____

Date of Issue: March 2002

Pages as indicated by "App." are approved by:

(Signature)



(Authority)



(Stamp)

(Original date of approval)

07. MRZ. 2002

This sailplane is to be operated in compliance with information and limitations contained herein.

Flight manual DG-1000S

Warnings

- All sailplanes are very complex technical devices. If you don't use yours as it is intended and within the certified operating limitations or if you fail to carry out proper maintenance work, it may harm your health or place your life in danger.
- Prior to flying the aircraft read all manuals carefully and regard especially all warnings, caution remarks and notes given in the manuals.
- Never take off without executing a serious pre-flight inspection according to the flight manual!
- Always respect the relevant safety altitudes!
- Respect the stall speeds and always fly with a safety margin above the stall speed according to the flight conditions, especially at low altitudes and in the mountains.
- Use only the battery chargers as specified in the flight manual.
- Don't execute yourself any work on the control system except for greasing.
- Repairs and maintenance work should only be accomplished by the manufacturer or at certified repair stations rated for this type of work. A list of stations which have experience with DG aircraft may be obtained from DG Flugzeugbau.
- Even if no annual inspections are required in your country, have your aircraft checked annually, see maintenance manual section 2.
- Please pay attention to our web-site www.dg-flugzeugbau.de. There you will find the latest technical notes and service information for your glider: www.dg-flugzeugbau.de/tech-mitteilungen-e
The „DG Pilot Info“ informs you immediately by e-mail about the publication of new technical notes and service information.
If you don't receive this info service, please send a mail to weber@dg-flugzeugbau.de with subject "DG Newsletter please" to receive this service free of charge.

Flight manual DG-1000S

0 Revisions

0.1 Record of revisions

Any revision of the present manual, except actual weighing data, must be recorded in the following table and in case of approved sections endorsed by the responsible airworthiness authority.

The new or amended text in the revised page will be indicated by a black vertical line in the right hand margin, and the Revision No. and the date will be shown on the bottom left hand of the page.

Rev. No.	Affected Pages/ section	Description	Issue Date	LBA Approval Date	Inserted Date Signature
1	0.3-0.5, 2.1, 2.9, 2.11, 4.5, 5.4, 6.3, 6.5, 6.10, 7.10	Manual revision TN 413/2	September 2003	Sept. 25. 2003	
2	0.3, 2.12, 3.2, 4.3	Manual revision TN 413/3	May 2004	May 10. 2004	
3	0.3, 0.5, 4.5, 7.6	Ballast box in the fin TN 413/4	June 2004	June 29. 2004	
4	0.3, 0.5, 3.2, 7.11	Canopies Gas-struts TN 413/6	October 2004	January 13. 2005	
5	0.3, 0.4, 2.7, 3.5, 4.1, 4.17	Manual revision TN 413/8	January 2005	February 22. 2005	
Rev. No.	Affected Pages/ section	Description	Issue Date	EASA Approval Date	Inserted Date Signature
6	0.1, 0.4, 0.5, 4.9, 4.13, 7.5	landing gear positive locking device TN1000/13	February 2008	April 8. 2008	
7	0.3, 0.5, 2.5, 2.9, 2.12, 7.13	Rudder pedals-loops (safety bows), manual revisions TN1000/16	May 2008	June 11. 2008	

Flight manual DG-1000S

0.1 Record of revisions continued

Rev. No.	Affected Pages/ section	Description	Issue Date	EASA Approval Date	Inserted Date Signature
8	0.5, 9.1-9.12	Electrically operated main landing gear	November 2008	28 January 2009	
9	0.6, 9.1, 9.2, 9.13	Special equipment for very small pilots TN1000/17	May 2010		

Flight manual DG-1000S

0.2 List of effective pages

Section		page	issued	replaced/	replaced/
0		0.0	March 2002		
		0.1	see manual	amendments	
		0.2		"	
		0.3		"	
		0.4		"	
		0.5		"	
		0.6	March 2002		
1		1.1	"		
		1.2	"		
		1.3	"		
		1.4	"		
		1.5	"		
		1.6	"		
	2	App.	2.1	March 2002	Sept. 2003
"		2.2	"		
"		2.3	"		
"		2.4	"		
"		2.5	"	May 2008	
"		2.6	"		
"		2.7	"	January 2005	
"		2.8	"		
"		2.9	"	Sept. 2003	May 2008
"		2.10	"		
"		2.11	"	Sept. 2003	
"		2.12	"	May 2004	May 2008
3		"	3.1	March 2002	
	"	3.2	"	May 2004	Oct. 2004
	"	3.3	"		
	"	3.4	"		
	"	3.5	"	January 2005	
4	"	4.1	March 2002	January 2005	
	"	4.2	"		
	"	4.3	"	May 2004	
	"	4.4	"		
	"	4.5	"	Sept. 2003	June 2004

Flight manual DG-1000S

0.2 List of effective pages (cont.)

Section		Page	issued	replaced/	replaced/
4	App.	4.6	March 2002		
		4.7			
	"	4.8	"		
	"	4.9	"	Febr. 2008	
	"	4.10	"		
	"	4.11	"		
	"	4.12	"		
	"	4.13	"	Febr. 2008	
	"	4.14	"		
	"	4.15	"		
	"	4.16	"		
	"	4.17	"	January 2005	
	"	4.18	"		
	"	4.19	"		
	"	4.20	"		
	"	4.21	"		
	"	4.22	"		
"	4.23	"			
"	4.24	"			
5	"	5.1	March 2002		
	"	5.2	"		
	"	5.3	"		
	"	5.4	"	Sept. 2003	
	App.	5.5	"		
		5.6	"		
		5.7	"		
6		6.1	March 2002		
		6.2	"		
		6.3	"	Sept. 2003	
		6.4	"		
		6.5	"	Sept. 2003	
		6.6	"		
		6.7	"		
		6.8	"		
		6.9	"		
		6.10	"	Sept. 2003	
		6.11	"		

Flight manual DG-1000S

0.2 List of effective pages (cont.)

Section	Page	issued	replaced/	replaced/
7	7.1	March 2002		
	7.2	"		
	7.3	"		
	7.4	"		
	7.5	"	Febr. 2008	
	7.6	"	June 2004	
	7.7	"		
	7.8	"		
	7.9	"		
	7.10	"	Sept. 2003	
	7.11	"	Oct. 2004	
	7.12	"		
	7.13	"	May 2008	
8	8.1	March 2002		
	8.2	"		
	8.3	"		
	8.4	"		
	8.5	"		
	8.6	"		
9	9.1	March 2002	May 2010	
	9.2	"	May 2010	
	9.3	"		
	9.4	"		
	9.5	"		
	9.6	"		
	9.7	"		
	9.8	"		
	9.9	"		
	9.10	"		
	9.11	"		
	9.12	"		
	9.13	May 2010		

Flight manual DG-1000S

0.3 Table of contents

	Section
General (a non-approved section)	1
Limitations (an approved section)	2
Emergency procedures (an approved section)	3
Normal procedures (an approved section)	4
Performance (a partly approved section)	5
Mass (weight) and balance (a non-approved section)	6
Sailplane and systems description (a non-approved section)	7
Sailplane handling, care and maintenance (a non-approved section)	8
Supplements	9

Flight manual DG-1000S

1 General

Section	Page
1.1 Introduction.....	1.2
1.2 Certification basis	1.2
1.3 Warnings, cautions and notes	1.3
1.4 Descriptive data	1.4
1.5 3 view drawing.....	1.6

Flight manual DG-1000S

1.1 Introduction

The sailplane flight manual has been prepared to provide pilots and instructors with information for the safe and efficient operation of the DG-1000S glider.

This manual includes the material required to be furnished to the pilot by JAR Part 22. It also contains supplemental data supplied by the glider manufacturer.

1.2 Certification basis

This type of sailplane has been approved by the Luftfahrt-Bundesamt (LBA) in accordance with:

Airworthiness requirements:

JAR Part 22 „*Sailplanes and powered sailplanes*“, change 5, issued 28th October 1995.

The Type Certificate No. 413 has been issued on March 12. 2002.

Category of Airworthiness: "Utility" or

„Aerobatic“ with 18m span without waterballast and if the required equipment is installed.

Flight manual DG-1000S

1.3 Warnings, cautions and notes

The following definitions apply to warnings, cautions and notes used in the flight manual.

"Warning"	means that the non observation of the corresponding procedure leads to an immediate or important degradation of the flight safety.
"Caution"	means that the non observation of the corresponding procedure leads to a minor or to a more or less long term degradation of the flight safety.
"Note"	draws the attention on any special item not directly related to safety but which is important or unusual.

Flight manual DG-1000S

1.4 Descriptive data

The DG-1000S is a two-place high performance sailplane for training and cross country flying and in addition for aerobatic training.

The DG-1000S is available with different spans:

- A) Wing constructed from carbonfibre reinforced plastics with parting at $y=8,6\text{m}$ and wing tips for 20 m span with Winglets.
Wing tips for 18 m span are optional.
- B) Wing constructed from carbonfibre reinforced plastics with 18 m span without parting.
Parting at $y=8,6\text{m}$ is optional

- Automatic hook ups for all controls.
- Comfortable seating and modern cockpit design similar to the DG-single-seaters - safety cockpit.
- Large 2 piece canopy for very good in-flight vision.
- Draught free canopy demist and 1 adjustable swivel air vent for each pilot.
- Sealed airbrake and landing gear boxes.
- Controls in each cockpit.
- All controls are operated with the left hand, which enables the right hand to remain on the control stick.

The DG-1000S is available with 3 different versions of the undercarriage:

- A) Very high spring mounted retractable main wheel with disc-brake, tail wheel.
- B) High spring mounted retractable main wheel with disc-brake, tail wheel and nose wheel
- C) Fixed spring mounted main wheel with drum-brake, tail wheel and nose wheel.

The main undercarriages versions B and C are interchangeable.

Other characteristics:

Waterballast in the wings and in the fin are optional with 18m span and standard with 20m span.

Standard: A ballast-box is installed in the fin. It can be used to compensate the mass of the rear pilot and as a trim-possibility for heavy pilots.

Max. ballast capacity: 12 kg.

Option: 2 ballast boxes in the front cockpit. The trim-weights used for the trim-ballast box in the fin also fit into these ballast boxes.

Flight manual DG-1000S

Technical data

Span	m	18	20
Wing area	m ²	16,72	17,53
Aspect ratio	/	19,38	22,82
Length	m	8,57	
Fuselage height	m	1,0	
Fuselage width	m	0,73	
Span of the horizontal tailplane	m	3,2	
Waterballast Wings	max. kg (l)	160	160
Waterballast fin	max. kg	6,2	
Trim ballast fin	max. kg	12	
Empty mass with basic instruments*	ca. kg	411	415
Wing loading (with one Pilot 80kg)	ca. kg/m ²	29,4	28,2
max. take off mass (max. TOW)	kg	750	750
max. wing loading	kg/m ²	44,9	42,8
Aerobatics		unlimited	simple
		Category „A“	
max. TOW for aerobatics and with fixed undercarriage	kg	630	630
max. speed	km/h	270	270

*Options will increase the empty mass accordingly!

1.5 Three view drawing

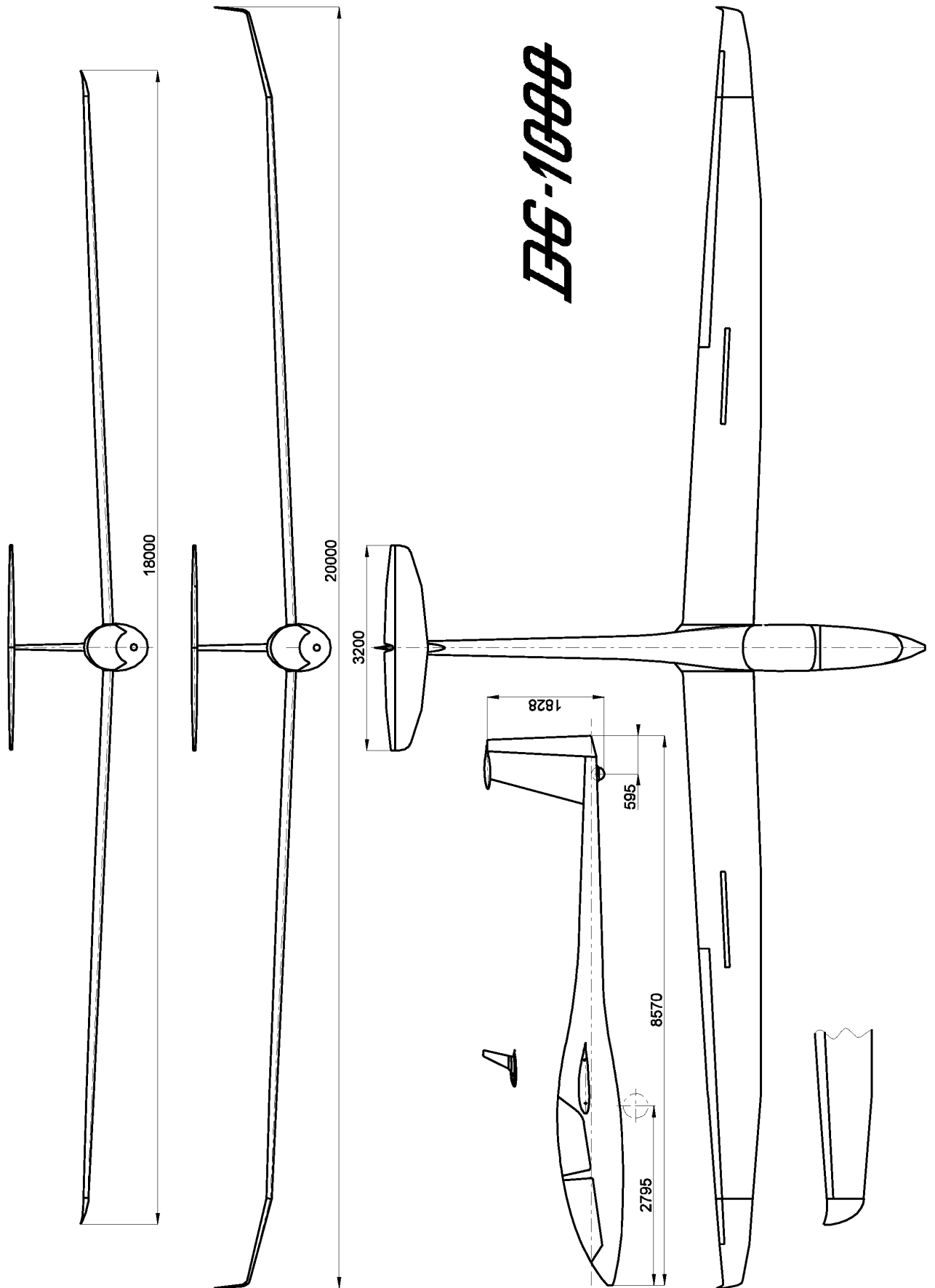

Flight manual DG-1000S

2 Limitations

Section	Page
2.1 Introduction.....	2.2
2.2 Airspeed	2.3
2.3 Airspeed Indicator Markings	2.4
2.4 Mass (weight).....	2.5
2.5 Centre of gravity	2.6
2.6 Approved manoeuvres	2.6
2.7 Manoeuvring load factors	2.7
2.8 Flight crew	2.7
2.9 Kinds of operation.....	2.8
2.10 Minimum equipment.....	2.9
2.11 Aerotow, winch and autotow launching	2.10
2.11.1 Weak links.....	2.10
2.11.2 Towing cables	2.10
2.11.3 Max. towing speeds	2.10
2.11.4 Tow Release.....	2.10
2.12 Crosswinds.....	2.10
2.13 Tyre Pressure	2.11
2.14 Waterballast (Option).....	2.11
2.15 Fin tank (Option).....	2.11
2.16 Trim ballast box in the fin.....	2.11
2.17 Limitations placards.....	2.12

Flight manual DG-1000S

2.1 Introduction

Section 2 includes operating limitations, instrument markings and basic placards necessary for safe operation of the glider, its standard systems and standard equipment.

The limitations included in this section have been approved by the LBA.

Flight manual DG-1000S

2.2 Airspeed

Airspeed limitations and their operational significance are shown below

	Speed	IAS km/h (kts.)	Remarks
V_{NE}	Never exceed speed	270 (146)	Do not exceed this speed in any operation and do not use more than 1/3 of control deflection.
V_{RA}	Rough air speed	185 (100)	Do not exceed this speed except in smooth air and then only with caution. Rough air is in lee-wave rotors, thunderclouds, visible whirlwinds or over mountain crests etc.
V_A	Manoeuvring speed	185 (100)	Do not make full or abrupt control movement above this speed, because under certain conditions the sailplane may be overstressed by full control movement.
V_W	Maximum winch-launching speed	150 (81)	Do not exceed this speed during winch- or auto-tow-launching
V_T	Maximum aero-towing speed	185 (100)	Do not exceed this speed during aerotowing.
V_{LO}	Maximum landing gear operating speed	185 (100)	Do not extend or retract the landing gear above this speed.

Warning: At higher altitudes the true airspeed is higher than the indicated airspeed, so V_{NE} is reduced with altitude according to the table below, see also section 4.5.5.

Altitude in [m]	0-3000	4000	5000	6000	7000	8000
V_{NE} indicated km/h	270	256	243	230	217	205

Altitude in [ft]	0-10000	13000	16000	20000	23000	26000
V_{NE} indicated kts.	146	138	131	124	117	111

Flight manual DG-1000S

2.3 Airspeed Indicator Markings

Airspeed indicator markings and their colour code significance are shown below.

Marking	(IAS) value or range km/h (kts)	Significance
Green Arc	88 – 185 (47.5 – 100)	Normal operating range (Lower limit is the speed $1,1 * V_{S1}$ with maximum mass and foremost C.G. Upper limit is the maximum rough air airspeed.)
Yellow Arc	185 – 270 (100 – 146)	Manoeuvres must be conducted with caution and only in smooth air.
Red Line	270 (146)	Maximum speed for all operations.
Yellow triangle	100 (54)	Approach speed at maximum weight without water ballast .

Flight manual DG-1000S

2.4 Mass (weight)

Category A „Aerobatic“

Maximum take off weight:	630 kg	1389 lbs.
Maximum landing weight:	630 kg	1389 lbs.

Category „Utility“:

with waterballast:

Maximum take off weight:	750 kg	1653 lbs.
Maximum landing weight:	750 kg	1653 lbs.

without waterballast: Maximum take-off and landing mass = $W_{NLP} + W_{wings}$

W_{NLP} = Maximum mass of the non lifting parts (see below)

W_{wings} = actual mass of the wings

Maximum weight of the non lifting parts = 469 kg 1034 lbs.

Caution: It is recommended to dump the waterballast before landing on airfields. Dump the ballast before an outlanding in any case.

Maximum mass in baggage compartment: 15 kg 33 lbs.

Caution: Heavy pieces of baggage must be secured to the baggage compartment floor (screwing to the floor or with belts). The max. mass secured on one half of the floor (left and right of fuselage centre line) should not exceed 7,5kg (16.5 lbs.).

Ballast

1. Maximum waterballast

in the wings:	160 kg	353 lbs.
in the fin	6,2 kg	13.7 lbs.

2. Maximum mass in the trim-ballast box in the fin: 12 kg 26.5 lbs.

The max. take off mass is not to be exceeded with 1. and 2. together.

Warning: Follow the loading procedures see section 6.

Flight manual DG-1000S

2.5 Centre of gravity

Centre of gravity range in flight is
190mm (7.48 inch) up to 440mm (17.32 inch) behind datum.

Datum = wing leading edge at the rootrib.
reference line = aft fuselage centre line horizontal.

C.G. diagrams and loading chart see sect. 6.

2.6 Approved manoeuvres

Category „Utility“:

The glider is certified for normal gliding in the "Utility" category.
Simple aerobatics are approved but only without waterballast and with the weight of the rear pilot compensated by ballast in the ballast box in the fin see section 6.8.7.

The following aerobatic manoeuvres are approved with all spans:

Spins	Chandelle
Inside loop	Turn
Lazy Eight	

Recommended entry speeds see section 4.5.8.1.

Category „Aerobatic“

Span 18 m without waterballast, max. mass 630 kg (1389 lbs.) and with the required equipment see section 2.10 installed and with the weight of the rear pilot compensated by ballast in the ballast box in the fin see section 6.8.7.

In addition to the manoeuvres in category „Utility“ the following manoeuvres are approved:

Inverted flight	half flick roll from normal to inverted flight with half loop
half loop and half roll	half flick roll from inverted to normal flight
half roll and half loop	
slow roll	

Recommended entry speeds see section 4.5.8.2.

Flight manual DG-1000S

2.7 Manoeuvring load factors

The following load factors must not be exceeded:

Category		Utility	Aerobatic
at manoeuvring speed	V_A	+5,3 -2,65	+7,0 -5,0
at max. speed	V_{NE}	+4,0 -1,5	+7,0 -5,0
with airbrakes extended	V_{NE}	+3,5 0	+3,5 0

2.8 Flight crew

a) single seated, only permissible in the front seat

max. load in the front seat 110 kg (242 lbs.)

min. load in the front seat see placard in cockpit and weighing report page 6.7

b) two seated

Either the front seat or the rear seat may be designated as seat of the pilot in command.

If the rear seat is to be designated it must be assured that all necessary operating items and instruments are installed and that the pilot in command has sufficient training in flying safely from the rear seat.

max. cockpit load is 210 kg (463 lbs.) with a max. of 105 kg (231 lbs.) in the front seat or 110 kg (242 lbs.) in the front seat and 90 kg (198 lbs.) in the rear seat.

min. cockpit load in the front seat is the min. cockpit load see a) minus 40% of the load in the rear seat. This means that 10 kg (22 lbs.) in the rear seat replaces 4 kg (8.8 lbs.) missing cockpit load in the front seat.

With these loads, the C.G. range given under 6.8 will be kept in the limits if the empty weight C.G. is in its limits. See loading chart in sect. 6.8.

Caution:

With lower pilot weights lead ballast must be added to the seat.

Ballast put on the seat (lead ballast cushion) must be fastened at the safety belt anchor point.

Option: Provision for removable trim-ballast in the front cockpit see sect 7.15.1.

Note: For Australia the lower limit for the min. load in the cockpit should not exceed 66 kg (146 lbs.). A provision for removable ballast see sect. 7.15.1 is mandatory.

2.9 Kinds of operation

A) All configurations

Flights according to VFR (daylight)

Aerotow

Winch- and auto-launching

B) In addition when flying without waterballast

1. Cloud flying (daylight): permitted when properly instrumented (see section 2.10).
2. Simple aerobatics see sect. 4.5.8.1. Category „Utility“
3. Aerobatics see section 4.5.8.2. Category „Aerobatic“ if the required equipment (see section 2.10 c) is installed, only with 18 m span.

Note: Cloud flying is not permitted in the USA, Canada and Australia.

Flight manual DG-1000S

2.10 Minimum equipment

As minimum equipment only the instruments and equipment specified in the equipment list (see maintenance manual) are admissible.

Note: The actual equipment list is filed in the enclosures of the maintenance manual.

a) Normal operation

Airspeed indicator Range: 0-300 km/h (0-165kts.);

Speed range markings see sect. 2.3

Altimeter Range: 0 – min. 10.000 m,

Altimeter with fine range pointer, 1 turn max. 1000 m (3000 ft.)

Four piece symmetrical safety harness

VHF - transceiver (ready for operation)

Outside air temperature gauge with probe in the fuselage nose.

Marking blue for temperatures below 2°C, (36°F).

Battery Z110 or a ballast weight of 5.75kg (12.7 lbs.) installed in the battery box in the fin

Parachute automatic or manual type or a suitable firm back cushion

approximately 8 cm (3 in.) thick for the front seat and 3 – 8 cm (1 – 3 in.) thick for the rear seat

Required placards, check lists

Flight and maintenance manual.

b) In addition for cloud flying

(Not permitted in the USA, Canada and Australia)

Variometer

Turn and bank indicator

c) In addition for aerobatics (Category Aerobatic)

Accelerometer capable of retaining max. and min. g-values

with markings red radial lines at +7 g and -5 g.

Remark:

Experience has shown that the installed airspeed indicator system may be used for cloud flying.

Flight manual DG-1000S

2.11 Aerotow, winch and autotow launching

2.11.1 Weak links

max. 10000 N \pm 10%

max. 2200 lbs. \pm 10%

2.11.2 Towing cables

For aerotow 30-70 m (100 - 230 ft)

Material: hemp- or plastic fibres

2.11.3 Max. towing speeds

Aerotow	$V_T =$	maximum 185km/h	maximum 100 kts.
Winch- and autotow	$V_W =$	150 km/h	81 kts.

2.11.4 Tow Release

The C.G. tow release (installed in front of the main wheel) is suitable only for winch- and auto launching..

The nose hook is to be used only for aerotow.

2.12 Crosswinds

The demonstrated crosswind velocity is 15 km/h (8 kts.) according to the airworthiness requirements.

Flight manual DG-1000S

2.13 Tyre Pressure

Main wheel	2,5 bar	(36 psi)
Nose wheel (if installed)	2,5 bar	(36 psi)
Tail wheel	4,0 bar	(58 psi)

2.14 Waterballast (Option)

Max. capacity 80 l (21.1 U.S. gal) per wing.

Filling the water ballast is only allowed with a filling system which enables determination of the exact amount of ballast filled, e.g. water gauge or calibrated canisters. Only symmetrical loading is allowed.

After filling, balance the wings by dumping enough water from the heavy wing, see 4.2.2.

Flight with leaking watertanks is prohibited, as this may result in asymmetrical loading condition.

Warning: Follow the loading chart, see section 6.8.
The max. take off weight must not be exceeded.

2.15 Fin tank (Option)

Warning: As it is dangerous to fly with empty wing tanks while ballast is resting in the fin, **it is prohibited to fill water into the fin tank if there is any risk of icing.** The flight conditions must comply with the following table:

min. ground temperature	°C	13,5	17	24	31	38
	°F	56	63	75	88	100
max. flight altitude	m	1500	2000	3000	4000	5000
	ft	5000	6500	10000	13000	16500

**In addition the outside air temperature OAT gauge is to be watched.
The OAT should not be lower than 2°C (36°F)!**

2.16 Trim ballast box in the fin

A box for ballast (trim-weights) is installed in the fin. It can be used to compensate the mass of the rear pilot and as a trim-possibility for heavy pilots.

Warning: Follow the loading chart see 6.8.7.

Tape the cover of the fin ballast box with tape min. 19mm (3/4 in.) wide prior to each flight.

Flight manual DG-1000S

2.17 Limitations placards

DG Flugzeugbau GmbH		
Type: DG – 1000S Serial No.: 10- S		
Year of construction:		
Maximum airspeeds	km/h	kts.
Winch launching	150	81
Aero-tow	185	100
Manoeuvring V_A	185	100
Rough air	185	100
Maximum speed V_{NE}	270	146
Approved aerobatic manoeuvres, only without waterballast:		
<i>Pos. Loop, Chandelle, Spin, Stall turn</i>		
In addition Category A:		
Only with 18 m span without waterballast:		
<i>Half loop and half roll, half roll and half loop, slow roll, inverted flight, half positive flick roll from normal flight with half loop, half negative flick roll from inverted flight</i>		
Maximum mass:		
Category A	630 kg	1389 lbs.
Category U	750 kg	1653 lbs.
Category U without waterballast	kg	lbs.

Other cockpit placards see section 7

**Gepäck max. 15 kg
baggage max. 33 lbs.**

**Sollbruchstelle 10000 N
rated load 2200 lbs.**

**Reifendruck 4 bar
Tyre pressure 58 psi**

Tail wheel

**Reifendruck 2,5 bar
Tyre pressure 36 psi**

Main wheel

**Reifendruck 2,5 bar
Tyre pressure 36 psi**

Nose wheel (if installed)

**Ballast box in the fin
Min. load in the front seat**

box empty
 
 box filled

At the control-light in the front instrument panel

Loading chart					
Cockpit load	front seat		rear seat		(Parachute included)
maximum	110 kg	242 lbs.	90 kg	198 lbs.	
or maximum	105 kg	231 lbs.	105 kg	231 lbs.	
minimum	kg	lbs.	/	/	

With lower pilot weight necessary ballast must be added.

Cockpit Check

1. Lead ballast (for under weight pilot)?
2. Parachute worn properly?
3. Safety harness buckled?
4. Front seat: pedals adjusted?
Rear seat: seating height adjusted?
5. All controls and knobs in reach?
6. Altimeter?
7. Dive brakes cycled and locked?
8. Positive control check ? (One person at the control surfaces).
9. Fin ballast tank emptied or correct amount filled in?
10. Trim ballast box in the fin, correct amount filled in?
Locking device completely engaged?
11. Trim?
12. Both canopies locked?
13. Runway free?

limits for use of the waterballast tank

minimum ground temperature	°C	13.5	17	24	31	38
	°F	56	63	75	88	100
maximum flight altitude above GND	m	1500	2000	3000	4000	5000
	ft.	5000	6500	10000	13000	16500

Warning:

Rigging of the horizontal tailplane is only permitted with nose down trim-setting!

Altitude in [m]	0-3000	4000	5000	6000	7000	8000
V_{NE} IAS km/h	270	256	243	230	217	205
Altitude in [ft]	0-10000	13000	16000	20000	23000	26000
V_{NE} IAS kts.	146	138	131	124	117	111

at the upper left hand side of the fin

Flight manual DG-1000S

3 Emergency procedures

Section	Page
3.1 Introduction.....	3.2
3.2 Canopy jettison	3.2
3.3 Bailing out.....	3.2
3.4 Stall recovery	3.2
3.5 Spin Recovery	3.3
3.6 Spiral dive recovery	3.3
3.7 Recovery from unintentional cloud flying.....	3.3
3.8 Flight with asymmetric waterballast.....	3.4
3.9 Defective fin ballast dump.....	3.4
3.10 Emergency wheel up landing.....	3.4
3.11 Emergency ground loop.....	3.5
3.12 Emergency landing on water	3.5

Flight manual DG-1000S

3.1 Introduction

Section 3 provides a checklist and amplification for coping with emergencies that may occur. Emergency situations can be minimized by proper pre-flight inspections and maintenance.

Caution: Canopy jettison and bailing out should be trained several times on the ground before flying the aircraft.

3.2 Canopy jettison

To bail out the white-red canopy opening handle (left) has to be operated with your right hand. Open the canopy as far as possible.

If the canopy doesn't stay open (or is not blown away by the oncoming air), but is closed by the air pressure, you have to release the canopy in its closed position by operating the red emergency release handle (right) with your left hand, then push the canopy upwards.

The retaining lines will tear off.

The gas struts (if installed) will disengage automatically

3.3 Bailing out

First jettison both canopies, then open the safety harness and bail out.

The low walls of the front cockpit allow for a quick push-off exit.

3.4 Stall recovery

Easing the stick forward and picking up a dropping wing with sufficient opposite rudder the glider can be recovered from the stall.

To recognize and prevent the stall, please refer to section 4.5.2.

Flight manual DG-1000S

3.5 Spin Recovery

Apply full opposite rudder against direction of the spin, pause.

Then ease stick forward until the rotation ceases, centralize the controls and carefully pull out of the dive.

The ailerons should be kept neutral during recovery.

Caution: To prevent unintentional spinning do not stall the sailplane. Fly with enough speed reserve especially in gusty conditions and in the landing pattern. Intentional spins with waterballast are not permitted.

Height loss during recovery	ca. 50-100 m (160-320ft)
max. speed during recovery	max. 200 km/h (108 kts.)

3.6 Spiral dive recovery

Apply rudder and aileron in opposite direction and carefully pull out of the dive.

Spiral dive occurs only when spinning more than 2 turns with medium C.G. positions, see section 4.5.8.

To prevent spiral dives intentional spinning should only be executed at aft C.G. positions.

Recovery from unintentional spinning should be done immediately.

3.7 Recovery from unintentional cloud flying

Spins are not to be used to loose altitude. In an emergency, pull out the dive brakes fully before exceeding a speed of 200 km/h and fly with max. 200 km/h (108 kts.) until leaving the cloud.

At higher speeds up to V_{NE} pull out the dive brakes very carefully because of high aerodynamic and g-loads.

Flight manual DG-1000S

3.8 Flight with asymmetric waterballast

If you suspect that the waterballast does not dump symmetrically you have to close the dump valves of the wingtanks immediately, to avoid greater asymmetry.

Asymmetry can be verified by the necessary aileron deflection in straight flight at low airspeeds.

When flying with asymmetric waterballast you have to increase the airspeed, especially in turns, so that you can avoid a stall at all costs.

Fly the landing pattern and touch down approx. 10 km/h (6 kts.) faster than usually and after touch down control carefully the bank angle to avoid the wing touching the ground too early.

3.9 Defective fin ballast dump

If the fin ballast dump valve handle can be operated with unusually low effort (force of the retaining spring is no longer apparent), you must assume that the fin ballast may no longer be dumped. In such a case, to avoid unsafe rearward C.G position, do not dump the wing ballast. Take into account the high mass of your glider and especially for the landing, increase the approach speed accordingly.

3.10 Emergency wheel up landing

It is not recommended to execute a wheel up emergency landing, as the energy absorption capability of the fuselage is much smaller than that of the landing gear.

If the landing gear can't be extended touch down with small angle of attack.

3.11 Emergency ground loop

If there is the risk of overshooting the landing strip you have to decide at least 40 m (130 ft) before the end of the field to execute a controlled ground loop:

- If possible turn into the wind!
- At the same time try to lift the tail by pushing the stick forward.

3.12 Emergency landing on water

From the experience with emergency water landing we know that it is likely that the sailplane will dive into the water, cockpit first.

Therefore an emergency landing on water should be the last choice. In the case of a water landing, however, extend the landing gear.

Recommended procedures :

On downwind leg of the landing pattern: Extend the landing gear, unlock the parachute harness (not the seat harness)

Touch down: With landing gear extended and airspeed as low as possible.

At point of touch-down: Use your left arm to protect your face against possible canopy fracture.

After touch down: Unfasten seat belt harnesses and undo parachute.

Leaving the cockpit under water: If the canopy has not fractured, opening the canopy may be possible only after the forward fuselage is almost completely filled with water.

Flight manual DG-1000S

4 Normal procedures

Section	Page
4.1 Introduction.....	4.2
4.2 Rigging and derigging, filling the watertanks	4.2
4.2.1 Rigging.....	4.2
4.2.2 Filling the wing water ballast tanks	4.4
4.2.3 Filling the fin ballast tank	4.5
4.2.4 Ballast box in the fin	4.5
4.2.5 Derigging	4.6
4.3 Daily Inspection	4.7
4.4 Pre-flight inspection.....	4.10
4.5 Normal procedures and recommended speeds	4.11
4.5.1 Launch.....	4.11
4.5.2 Free flight.....	4.12
4.5.3 Approach and landing.....	4.13
4.5.4 Flight with water ballast.....	4.15
4.5.5 Flight at high altitude and at low temperatures	4.16
4.5.6 Flight in rain and thunderstorms	4.17
4.5.7 Cloud flying	4.17
4.5.8 Aerobatics	4.18

Flight manual DG-1000S

4.1 Introduction

This section provides checklist and amplification procedures for the conduct of normal operation. Normal procedures associated with optional systems can be found in section 9.

4.2 Rigging and derigging, filling the watertanks

4.2.1 Rigging

1. Open the rear canopy.
2. Clean and lube the pins, bushings and the control connections.
3. Rigging the inboard wing panels
All controls hook up automatically. Therefore set the airbrake handle to the forward stop.

Ailerons should be held neutral for rigging, airbrakes must be locked.

Screw one of the rear wing securing pins on the tool W 38/2.

Close both canopies. Push the right wing panel into place. Insert the rear securing pin with the tool at the rear attachment fitting. Push in the tool so far that the upper surface of the brass part of the tool is flush with the wing surface. Screw off the tool. Check if the locking device for the securing pin has engaged.

Note: If the wing refuses to slip close to the fuselage, you may try to insert the rigging pin W58 instead of the locking pin and try to move the wing towards the fuselage with help of the conical shape of this pin.

Screw the other securing pin onto the tool.

Open the rear canopy. Push in the left wing. Mount and check the left securing pin by the same method as the right side.

Push the two main pins in as far as possible.

Turn the handles up to the fuselage wall, while pulling out the white securing knob, then release the knob back to its locked position.

Flight manual DG-1000S

4. Rigging of the stabilizer

Install the battery Z110 or a ballast weight of 5.5kg (12.1 lbs.) in the battery box in the fin, connect the battery.

Warning: Rigging of the horizontal tailplane is only permitted with **nose down** trim-setting. Therefore operate the trim release lever and push the control stick forward, then release the lever to engage the trim (don't operate the trim control knob, the trim should not be pushed to the most nose down position).

Screw the tool W 38/2 into the securing plate (near the top of the left surface of the fin). Pull out the securing plate with the tool, move it downwards to engage in the rigging position. Set the stabilizer on, so that the roller at the fuselage side push rod is inserted into the funnel at the elevator.

Watch carefully the procedure!

When the stabilizer is set down and laying on the fin, push it aft. The roller will engage and slide forward in the funnel if you hold the elevator in the pertinent position.

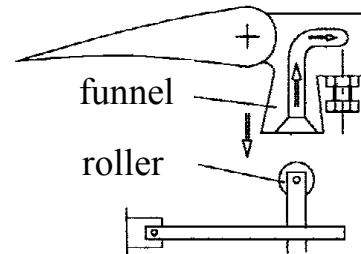

Release the securing device by pulling out with the tool and engage the securing device by lifting the tool. The securing plate must be flush with the surface of the fin. Screw out the tool.

Check for correct elevator connection by looking from the rear into the gap at the right hand side of the rudder.

5. Rigging of the outboard wing panels (20m wing extensions or 18 m wing tips): Insert the wing tip extensions into the wing. Press in the locking pin with your finger.

Insert the wing tip as far as the aileron connector starts to slide onto the aileron.

Strike firmly with the palm of your hand on to the wing tip to lock in the wing tip extension.

6. Tape the gaps of the wing-fuselage junction and at the wing joint.

7. Execute a positive control check, one helper to hold firmly the control surfaces is needed.

Flight manual DG-1000S

4.2.2 Filling the wing water ballast tanks

First open the fin tank and then open the right wing tank valve (top handle). Place the right wing tip on the ground. Attach the hose in the water outlet on the lower surface of the wing. Fill with water. Close the valve.

Place the left wing tip to the ground and fill the left tank accordingly. Filling with water ballast is only allowed with a filling system which enables you to determine the exact amount of ballast filled in, e.g. water gauge or calibrated canisters.

Warning: Fill the hose from your water containers but never from a main pressure water supply. Filling the wing tanks with excessive pressure (more than 0.2 bar, 3 psi) will definitely burst the wing shell!

Caution: If the tanks are to be filled up completely you must suck the air out of the tanks with the filling hose, as the tanks have no ventilation line.

Fill with the desired amount of water regarding the loading chart see section 6.8.5.

In case a valve leaks slightly, you may try to pull out the PVC pushrod of the valve to stop the leak. If this cannot be done successfully refer to maintenance manual 1.8.1. and 4.1.

It is not allowed to fly with leaking watertanks, as this may result in asymmetrical loading condition.

After filling the tanks, check to see if the wings are balanced. If one wing is heavier, dump enough water to balance the wings.

Finally press the Teflon-glass-fabric which shall close the dump holes against the wing-shell. There must be always a small amount of grease on the shell, to ensure that the covers stick to the shell.

Warning: Follow the loading chart section 6.8 must be observed. The maximum take off weight must not be exceeded.

4.2.3 Filling the fin ballast tank

This tank must be filled after filling the wingtanks. Determine the amount (see section 6.8.6). Connect the transparent funnel equipped filling hose (supplied with the aircraft) via the hose connector GRS 10-12 to the hose which comes out of the left rear end of the fuselage.

The funnel can be suspended at the top of the rudder.

Fill with clean water using a graduated measuring vessel.

In addition you may check the content level by holding the filling hose against the scale on the fin.

After filling, push the fin tank dump lever in a forward direction (the dump valve will be closed by a spring).

Then remove the filling hose with the hose connector.

4.2.4 Ballast box in the fin

To fill the ballast box remove the Plexiglas cover plate by inserting a 6mm pin into the hole of the upper locking device and move the locking pin downwards. Determine the amount of trim-weights according to section 6.8.7. Slide the weights into the rails of the box. The heavy weights with 2,4 kg (5.3 lbs.) each must be installed in the lower 4 sections and the lighter weights with 1,2 kg (2.65 lbs.) each in the upper 2 sections. It doesn't matter in which sections the weights are installed (in case that not all sections will be filled up), but it is not allowed to insert the light weights into the sections for the heavy weights. Close the compartment.

Warning: Check that the locking device has engaged completely.

Tape the cover of the fin ballast box with tape min. 19mm (3/4 in.) wide prior to each flight.

A control light in the front instrument panel starts blinking after each transaction with the weights. By counting the amount of blinks, the amount of ballast can be determined. For a heavy weight 2 blinks appear and 1 blink for a light weight, this means 10 blinks if the box is filled up completely. After a pause of 2-3 seconds the blinking will be repeated etc. The blinking can be stopped by pressing on the control light. Pressing again on the control light reactivates the blinking feature.

After filling the ballast box you should check the correct indication of the control light.

In addition with TN413/4 executed, standard from ser. no. 10-49 on:

A switch will be operated by the locking pin of the ballast box cover.

As long as the switch is not closed, the control light for the ballast box will blink with doubled speed without interruption. The blinking can't be switched off by pressing on the control light contrary to the blinking which indicates the amount of ballast.

Flight manual DG-1000S

4.2.5 Derigging

Derigging follows the reverse of rigging.

Waterballast must be dumped first.

Lock the airbrakes.

For disassembling the securing pins of the wings the tool W 38/2 must be screwed into the thread completely.

The brass part of the tool will then disengage the securing of this bolt.

It is recommended to leave the securing pin in the right wing while you derig the left wing.

Derigging of the outboard wing panels (20m wing extensions or 18 m wing tips):

Use a 6 mm diameter pin for pressing in the locking pin on the wings upper side.

Pull out the wing tip or the wing tip extension.

Flight manual DG-1000S

4.3 Daily Inspection

Please keep in mind the importance of the inspection after rigging the glider and respectively each day prior to the first take off. It is for your safety.

Caution: After a heavy landing or if other high loads have been imposed on your sailplane, you must execute a complete inspection referring to maintenance manual sect. 2.3 prior to the next take off. If you detect any damage, don't operate your aircraft before the damage is repaired. If the maintenance and repair manual don't give adequate information, please contact the manufacturer.

A Inspection prior to rigging:

1. Wing roots and spar ends
 - a) check for cracks, delamination etc.;
 - b) check the bushes and their glued connection in root ribs and the spar ends for wear;
 - c) check the control hook ups at the rootrib for wear and corrosion;
 - d) check the strings which hold the waterbags for sufficient tension (see maintenance manual sect. 4.1)
2. Fuselage at wing connection
 - a) check the lift pins for wear and corrosion;
 - b) check the control hook ups including the water dump system for wear and corrosion.
3. Top of the vertical fin
 - a) check the mounting points of the horizontal tailplane and the elevator control hook up for wear and corrosion
 - b) check if the battery is installed in the fin and connected
4. Horizontal tailplane
check the mounting points and the elevator control hook up for wear and corrosion;
5. Rigging points for the outboard wing panels
check the lift pins and bushes for wear and corrosion and check their glued connections. Check the locking device for function and sufficient spring force.

Flight manual DG-1000S

B Inspection after rigging - Walk around the aircraft

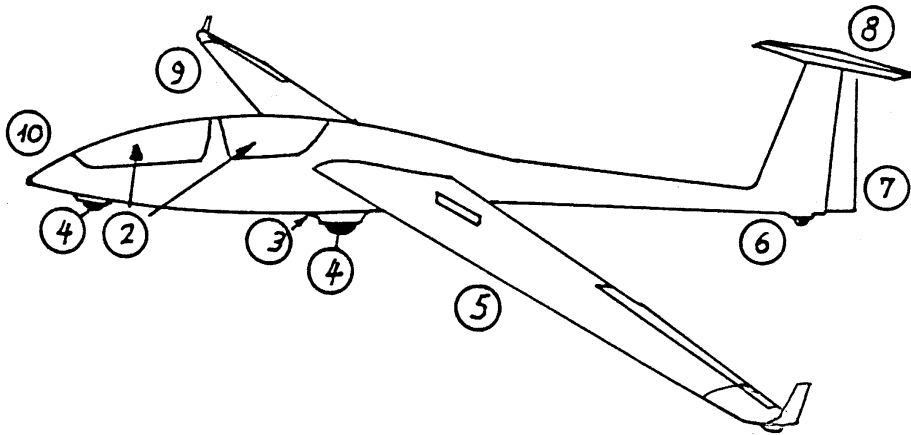

1. All parts of the airframe
 - a) check for flaws such as bubbles, holes, bumps and cracks in the surface;
 - b) check leading and trailing edges of the wings and control surfaces for cracks;
2. Cockpit area
 - a) check the canopy locking mechanism;
 - b) check the canopy emergency release see section 7.14 (not each day, but min. every 3 month);
 - c) check the main pin securing;
check the securing ropes of the headrest (not applicable for the Version mounted at the lift pin tube);
 - d) check all controls for wear and function, incl. positive control check;
 - e) check the tow release system for wear and function incl. cable release check;
 - f) check for foreign objects;
 - g) check the instrumentation for wear and function;
 - h) check the radio and other parts of the electric system (fuses!) for function. If there is no electrical power, it can be expected that the battery in the fin is not fitted. **Flying without this battery is not permitted, as otherwise the forward C.G. limit may be exceeded**
 - i) check the brake fluid level;
 - j) check if the fin tank is empty
3. C.G. Tow hook
 - a) check the ring muzzle of the C.G. hook for wear and function;
 - b) check for cleanliness and corrosion;

Flight manual DG-1000S

4. Main landing gear and nose wheel (if fitted)
 - a) check the struts, the gear box, the gear doors and the tyre for wear; dirt in the struts can hinder the landing gear from locking over centre the next time!;
With TN1000/13 executed, standard from ser. no. 10-133 on:
Check all parts of the landing gear positive locking device (notch and latch at the landing gear struts) for dirt. Check the Bowden cable for damage.
 - b) check the tyre pressure;
main wheel: 2.5 bar - 36 psi
nose wheel: 2.5 bar - 36 psi
 - c) check wheel brake and hose for wear and function;
5. Left wing
 - a) check locking of the outboard wing;
 - b) check the aileron for excessive free play;
 - c) check airbrake- and box and control rod for wear and free play. It must be possible to retract the airbrake, even if it is pressed backwards in direction of flight. If there is any water in the airbrake box this has to be removed;
 - d) check the locking of the rear wing attachment pin.
6. Tail wheel
 - a) check for wear, free play and excessive dirt in the wheel box. Remove excessive dirt prior to take off;
 - b) check tyre pressure: 4 bar -58 psi;
7. Rear end of the fuselage
 - a) check the lower rudder hinge and the connection of the rudder cables for wear, free play and correct securing;
 - b) check the bulkhead and fin trailing edge shear web for cracks and delamination;
8. Fin - horizontal tail
 - a) check the upper rudder hinge for wear and free play;
 - b) check the elevator for free play and correct control hook up, look from the rear into the gap at the right hand side of the rudder;
 - c) check the securing of the stabilizer;
 - d) check the horizontal tail for free play;
 - e) check the TE or Multiprobe for correct insertion and fix it with tape
 - f) check the trim-weight box, correct number of weights, locking device completely engaged?
9. Right wing see item 5.
10. Fuselage nose
 - a) check the ports for the static pressure and the pitot pressure for cleanliness.
 - b) if the sailplane was parked in rain, you have to empty the static ports by sucking out the water at the ports.
 - c) check the nose hook for cleanliness and corrosion.

Flight manual DG-1000S

4.4 Pre-flight inspection

1. Lead ballast (for under weight pilot)?
2. Parachute worn properly?
3. Safety harness buckled?
4. Front seat: pedals adjusted?
Rear seat: seating height adjusted?
5. All controls and knobs in reach?
6. Altimeter?
7. Dive brakes cycled and locked?
8. Positive control check? (One person at the control surfaces).
9. Fin ballast tank emptied or correct amount filled in?
10. Trim-weight box in the fin, correct amount installed?
Locking device completely engaged?
11. Trim?
12. Both canopies locked?
13. Runway free?

4.5 Normal procedures and recommended speeds

4.5.1 Launch

Due to the towhook position being in the middle of the fuselage and the excellent effectiveness of the ailerons and rudder, the possibility of wing dropping or ground loops, even on a slowly accelerating aerotow is reduced. Take-off with strong crosswind is possible.

4.5.1.1 Aerotow

- a) Aerotow is permitted only using the nose tow release. Set trim to neutral for aerotow.
- b) Version with nose wheel: Pull the stick until the nose wheel lifts off from the ground. Then control the aeroplane so that nose wheel and tail wheel don't touch the ground.

Version without nose wheel: Keep the elevator in neutral position.

Don't try to lift off before you reach an airspeed of 80 km/h (43 kts.) (without ballast). On a rough airfield hold the control stick tight. The undercarriage can be retracted at safety height during the tow.

Normal towing speed is 120-130 km/h (65 - 70 kts.).

For a cross country tow the speed can be as high as 185 km/h (98 kts.).

Warning: Aerotow with high take off weight requires a powerful tow plane. Many tow planes are not certified to tow gliders with high take off weights. Reduce the take off weight if necessary!

Flight manual DG-1000S

4.5.1.2 Winch launch

Winch launch is only allowed at the C.G. tow hook!
Set the trim to neutral for winch launch.

Caution: During ground roll and initial take-off (especially when flying solo) push the control stick to a forward position to prevent excessive nose-up pitching rotation during initial take-off.

After reaching safety altitude gradually pull back on the stick, so that the glider will not pick up excessive speed. Don't pull too hard.
After reaching release altitude pull the tow release knob.

Recommended winch launch airspeed 110-120 km/h (60-65 kts.).

Caution: Do not fly at less than 90 km/h (49kts.) or not more than 150 km/h (81 kts.).

Warning: Winch launch with high take off weight requires a powerful winch!

4.5.2 Free flight

Stalling characteristics (level and turning flight)

When stalled the DG-1000S will warn by buffeting. If the stick is pulled further the DG-1000S will drop one wing.

Only at forward C.G. positions the DG-1000S can be flown in stall without wing dropping, maintain control during stalled flight only with the rudder, holding the ailerons neutral.

With stick forward and opposite rudder if required, the DG-1000S can be recovered without much loss of height. Rain does not influence this behaviour noticeably. The loss of height is ca. 50 m (160 ft).

Stall airspeeds see section 5.2.2.

Caution: Flights in conditions conducive to lightning strikes must be avoided.

4.5.3 Approach and landing

4.5.3.1 Normal landing

It is recommended to dump the waterballast before landing even on airfields. Dump the ballast before an outlanding in any case.

Abeam the landing point extend the landing gear. In calm weather approach with approx. 100 km/h (54 kts.) (ballast dumped!). With strong wind and / or waterballast fly faster! The very effective Schempp-Hirth dive brakes make a short landing possible. So a slip is not necessary as a landing technique.

Caution: While slipping the rudder is sucked in its displaced position. So it is recommended to practise slipping at a higher altitude.

The slip can be introduced at the recommended approach speed see above.

To recover from the slip neutralize the aileron control first, this will reduce the force which sucks the rudder in its displaced position.

During the slip the airspeed indicator shows airspeed values which are too low, so the slip must be executed with regard to the position of the horizon.

No influence on the slipping characteristics when slipping with partially filled waterballast is noticeable.

Strong crosswind offers no problem.

Do not approach too slowly with fully extended airbrakes otherwise the aircraft may drop during flare out. When flaring out keep the airbrake setting you were using, opening them further may drop the sailplane!

You can land the DG-1000S on soft fields with the landing gear extended, as there is no tendency of nosing over. During touch down pull the stick completely to avoid the fuselage nose touching the ground.

After landing in a muddy field clean the landing gear and tow releases.

Dirt in the front strut can keep the landing gear from locking over centre next time.

With TN1000/13 executed, standard from ser. no. 10-133 on:

Dirt in the landing gear positive locking device (notch and latch at the landing gear struts).may keep the latch from engaging in the notch next time.

Simply hosing with water is the best cleaning method (don't use a high pressure cleaner).

Flight manual DG-1000S

4.5.3.2 Landing with the landing gear retracted

Wheel-up landing is not recommended see emergency procedures section 3.10.

After wheel-up landing check the fuselage belly and the tow hook for damage.

4.5.3.3 Landing with asymmetric waterballast

See emergency procedures section 3.8

Flight manual DG-1000S

4.5.4 Flight with water ballast

4.5.4.1 Wing tanks

Recommended ballast for smooth thermals:

	rate of climb		ballast	
	m/s	fpm	litres	U.S. gallons
below	1,5	300		None
	1,5 – 3	300-600	100	26
more than	3	600		max. ballast

Do not exceed the maximum gross weight when loading the water ballast. The maximum quantity of water allowed is dependent on the empty weight and the cockpit load (see section 6.8.5).

In flight the water drains at approx. 0.5 lt./sec. (1.1 lbs./sec).

4.5.4.2 Fin water ballast tank

For optimal thermalling performance and handling water ballast in the fin tank should be used to compensate the forward movement of C.G. due to the mass of the wing water ballast. Please refer to section 6.8.6.

Warning: It is prohibited to use the fin tank in icing conditions see sect. 2.15.

Warning: If there is the risk of freezing, dump all water before you reach freezing altitude, latest at +2°C (36°F), or descend to lower altitudes.

If you suspect a tank is leaking, dump all water immediately.

Water ballast raises the approach speed, so it is recommended to dump the waterballast before landing. Dump the ballast before an outlanding in any case.

4.5.4.3 Filling the waterballast

See sections 4.2.2 and 4.2.3. After filling level the wings and check if the dump valves are tight. It is not allowed to fly with leaking watertanks as this may result in an asymmetric loading condition.

Flight manual DG-1000S

4.5.4.4 Dumping of the waterballast

First open the fin tank, then open both wing ballast tanks together. Do not empty one wing tank after the other to avoid an asymmetric loading condition.

Warning: If the fin ballast dump valve handle can be operated with unusually low effort (force of the retaining spring is no more apparent) you must suspect that the fin ballast can't be dumped any more. In such case don't dump the wing ballast to avoid an unsafe backward C.G. position.

4.5.4.5 Valves leaking, servicing

Please refer to the maintenance manual sect. 1.8 and 4.1.

4.5.5 Flight at high altitude and at low temperatures

With temperatures below 0°C (32°F) for instance when wave flying or flying in winter, it is possible that the control circuits could become stiffer. Special care should be taken to ensure that there is no moisture on any section of the control circuits to minimize the possibility of freeze up. It could be advantageous to apply Vaseline along all the edges of the airbrake cover plates to minimize the possibility of freezing closed.

Operate the controls regularly to prevent ice build-up.
It is not allowed to carry waterballast.

Caution:

1. At temperatures below -20°C (-4°F) there is the risk of cracking the gelcoat.
2. Attention must be paid to the fact that at higher altitudes the true airspeed is greater than the indicated airspeed.

The max. speed V_{NE} is reduced. See the following table:

Altitude in [m]	0-3000	4000	5000	6000	7000	8000
V_{NE} indicated km/h	270	256	243	230	217	205

Altitude in [ft]	0-10000	13000	16000	20000	23000	26000
V_{NE} indicated kts.	146	138	131	124	117	111

3. Dump the water ballast before you reach freezing altitude or descend to lower altitudes.
4. Do not fly below 0°C (32°F) when your glider is wet (e.g. after rain).

4.5.6 Flight in rain and thunderstorms

With light rain the stall speed and the sink rate increases slightly and the approach speed has to be increased.

Warning: Flights and especially winch launches in the vicinity of thunder storms should be avoided. Due to lightning discharge, carbon fibre structures may be destroyed.

4.5.7 Cloud flying

Cloud flying is only permitted without waterballast. Take care to fly smoothly and coordinated. It is prohibited to use a spin as a method for losing altitude in cloud. In case of emergency, pull out the dive brakes fully before exceeding a speed of 200 km/h and dive with max. 200 km/h (108 kts.) to leave the cloud.

Warning: Flying in or near thunderstorm-clouds is prohibited.

Flight manual DG-1000S

4.5.8 Aerobatics

Caution: The DG-1000S is a high performance sailplane. Therefore the speed increase in the dive, especially in inverted flight is high.

Training aerobatics therefore should only be executed after a rating with an experienced pilot, or if you can master the manoeuvres on other sailplane types. In any case don't try to execute the manoeuvres with entry speeds other than those listed.

Caution: Do not make full or abrupt control movement above the manoeuvring speed $V_A=185$ km/h (97 kts.). At speeds between V_A and $V_{NE}=270$ km/h (146 kts.) reduce the control movements accordingly. At V_{NE} only 1/3 of the max. control movements are allowed.

4.5.8.1 Category U, Utility

Warning: Execute only the approved manoeuvres.

Approved manoeuvres valid for all spans, but only without waterballast and with the weight of the rear pilot compensated by ballast in the ballast box in the fin see section 6.8.7.

Approved manoeuvres	Entry speed	g-loads
Spin	/	/
Inside loop	180 - 200 km/h (97 - 108 kts)	4.0
Chandelle	180 - 200 km/h (97 - 108 kts)	3.5
Lazy Eight	180 - 200 km/h (97 - 108 kts)	3.5
Stall turn	200 - 220 km/h (108 - 119kts)	4.0

Flight manual DG-1000S

Spins

Caution: Prolonged spinning is satisfactorily accomplished with aft C.G. positions. If prolonged spinning is intended, ballast in the ballast box in the fin should be used to achieve an aft C.G. position, see section 6.8.7.

It is not necessary to extend the dive brakes during spin recovery. The DG-1000S displays a large nose down pitch attitude after leaving the spin. So you have to flare out correspondingly.

With **medium and forward C.G. positions** prolonged spinning is not possible. The DG-1000S will terminate the spin by itself after a certain number of turns dependent on the C.G. position. The nose down pitch and speed will be high so with these C.G. positions not more than 1 turn spins should be executed, to avoid high g-loads.

In addition there is a tendency that the spin will turn into a spiral dive after 1 or 2 turns. On reaching this state you must recover immediately.

Inducing the spin: Gradually bring the sailplane into a stall. When buffeting starts, pull the stick back completely and kick in full rudder in the direction of spin.

Recovering from the spin: Apply full rudder opposite to the direction of spin, then ease stick forward until the rotation ceases, centralize the controls and carefully pull out of the dive. The ailerons should be kept neutral during recovery. Height loss during recovery is approx. 100 m (320 ft), the max. speed is 200 km/h (108 kts.).

Flight manual DG-1000S

Stall turn

To fly a stall turn safely, proceed as follows:

Don't choose an entry speed of less than 200 km/h (108 kts.).

During the pull out, when reaching the vertical flight path initiate rotation at min. 150 km/h (81 kts.) with the rudder. Push the rudder quickly, but not abruptly. During the turn apply a little aileron against the direction of turn and full forward stick deflection to execute the turn correctly in one plane.

As soon as you reach the vertical dive, start to pull out of the dive to minimize the increase of airspeed and the g-loads.

Be careful not to exceed the airspeed for max. control surface deflection as indicated in section 2.2.

Caution: A classical stall turn with almost no airspeed at the highest point of the turn is very difficult to fly with a glider with larger wingspan, due to the high moment of inertia.

This effect is taken into account when using the above mentioned procedure.

Only a pilot who is trained in the technique to execute during the pull up a slight side-slip (with a little aileron deflection in the intended turn direction and appropriate rudder deflection against turn direction) can start to initiate the rotation at a lower speed of 120 km/h (65 kts.) with fast rudder deflection. The turn will look nicer and be narrower than with the method described above.

Warning: If the rudder is applied too late and the rotation is insufficient, it is possible that the glider tailslides (falls tailwards) or falls sideways. If this happens it is important to hold all controls firmly, preferably at one of the stops, until the nose swings down. Otherwise, due to the reverse airflow, the control surfaces may flap against their stops and be damaged. In addition holding the control stick at the stop prevents the stick from making unnecessary movements due to the massbalance weights in the elevator control system. Then flare out immediately.

Flight manual DG-1000S

4.5.8.2 Category A, Aerobatic

Only approved with 18m span and without waterballast, max. mass 630 kg (1389 lbs.) and with the weight of the rear pilot compensated by ballast in the ballast box in the fin see section 6.8.7 and with the required equipment installed see section 2.10.

Execute only the approved manoeuvres.

Don't execute aerobatics below the safety altitude required by national law.

Approved manoeuvres (Category A, Aerobatic):

All manoeuvres approved for category U, Utility and additionally:

Approved manoeuvres	recommended airspeed	g-load
Inverted flight	120 - 200 km/h (65-108 kts.)	-1
Approved manoeuvres	entry speeds	g-loads
half loop and half roll	220 km/h (119 kts.)	+5.0
half roll and half loop	180 – 200 km/h (97-108 kts.)	+4.5
slow roll	180 - 200 km/h (97-108 kts.)	+/-1.5
half positive flick roll from normal to inverted flight with half pos. loop	120 - 140 km/h (65 - 76 kts.)	+4.0
half negative flick roll from inverted to normal flight	130 – 150 km/h (70 - 81 kts.)	-3.5

Caution: the DG-1000S is equipped with a powerful longitudinal trimming device. In addition the mass balance weight of the elevator is incorporated in the elevator control system. Due to these facts the elevator control forces during inverted flight change considerably with trim position.

It is strongly recommended to trim the glider to approx. 140 km/h (76 kts.) in horizontal flight prior to executing aerobatics, especially prior to inverted flight.

Flight manual DG-1000S

Inverted flight

The speed in inverted flight should preferably be chosen between 120-200 km/h (65-108 kts.). At speeds greater than 185 km/h (100 kts.) no full control deflections are allowed.

Warning:

When the speed is reduced below the minimum speed (depending on weight and C.G. position between 105 - 115 km/h, 57 - 62 kts.) the DG-1000S will stall. The stall will be indicated by buffeting of the tailplane. The stall starts with the stick somewhat away from its forward position. When applying full stick forward the DG-1000S will enter an inverted stable stall with high sink-rate. The aircraft nose will noticeably point below the horizon and the airspeed increases. The efficiency of the ailerons and rudder will not be reduced.

To avoid an uncontrolled flight condition or disorientation of the pilot, this manoeuvre should be terminated immediately by a half roll!

Half loop and half roll

After reaching the entry speed of 220 km/h (119kts.) pull the stick quickly, but not abruptly until reaching the inverted position.

Before the nose starts pointing below the horizon apply full aileron in the desired direction to induce the half roll. When the wing passes the vertical position the rudder must be applied upwards to keep the nose above the horizon.

Half roll and half loop

After reaching the entry speed of 180 - 200 km/h (97 - 108 kts.) the nose must be raised approx. 30° above the horizon. After returning the stick to neutral apply full aileron into the desired direction to start the half roll. When the wing passes the vertical position the rudder must be applied upwards. When reaching inverted flight the ailerons must be neutralized and before reaching the stall speed pull back the stick, but not too abruptly, to start the half loop to level out.

Note: If during the entry the nose is raised too high or the entry speed is too low, it can happen, that the glider continues to roll into normal upright position, even if the aileron was neutralized in inverted position .

Flight manual DG-1000S

Slow roll

After reaching the entry speed of 180 - 200 km/h (97-108 kts.) the nose must be raised slightly above the horizon. After returning the stick to neutral, full aileron has to be applied in the desired direction.

When the wing passes the vertical position the rudder must be applied a little in upwards direction.

After the wing has passed the first vertical position the stick is to be pushed slightly (never abruptly) forward to keep the nose above the horizon. When the wing passes the second vertical position the rudder must be applied upwards to keep the nose above the horizon until normal flying position is reached.

Note: If during the inverted flight the nose is raised too high above the horizon and the speed is reduced too much, a stall could occur when the wing reaches the second vertical position and the roll is finished as a "flicked" roll.

The stall is indicated by buffeting of the tailplane.

Flight manual DG-1000S

Flick manoeuvres

The flick manoeuvres which have been tested with the DG-1000S should only be executed by experienced aerobatic pilots. The result is dependent as for any other sailplane on several parameters like inducing control speed, C.G. position, control movement during rotation etc.

Due to the large span and the resulting large moment of inertia, executing flick manoeuvres is more difficult than with smaller aerobatic gliders. Therefore you should not try these manoeuvres solo unless you have trained and mastered them on other gliders

Half positive flick roll from normal to inverted flight with half positive loop

Tested entry speed: 120 – 140 km/h (65 – 76 kts.).

Prior to inducing the flick roll, place the nose a little below the horizon.

Induce the half roll with full stick backwards and full rudder only. After the rotation starts ease the stick to neutral to avoid too large an angle of attack and unnecessary loss of speed.

Stop the rolling motion in the inverted position by neutralizing the elevator control and with a little rudder against the rolling direction. Then pull the stick back to fly the half positive loop before the glider stalls in the inverted attitude. If you keep the stick pulled back for too long a time during entry, it may not be possible to stop the rotation in the inverted attitude and the glider will continue to roll into normal flight position.

Half negative flick roll from inverted to normal flight

Tested entry speed: 130 – 150 km/h (70 – 81 kts.).

Induce the half roll with full stick forwards and full rudder only. If you use additional aileron there may be some vibration in the fuselage due to vortices. The vibrations don't impair the flight characteristics.

Shortly before reaching normal upright position, the rotation has to be stopped by pulling the stick backwards and applying some opposite rudder.

Stopping the half roll in exactly horizontal attitude is nearly impossible. The glider will adopt a nose down position.

Flight manual DG-1000S

5 Performance

Section	Page
5.1 Introduction.....	5.2
5.2 Approved data.....	5.3
5.2.1 Airspeed indicator system calibration.....	5.3
5.2.2 Stall speeds.....	5.4
5.3 Additional Information	5.5
5.3.1 Demonstrated crosswind performance.....	5.5
5.3.2 Gliding performance	5.5
5.3.3 Flight polar with 20 m wing span	5.6
5.3.4 Flight polar with 18 m wing span	5.7

Flight manual DG-1000S

5.1 Introduction

This section provides approved data for airspeed calibration, stall speeds and take-off performance and non-approved additional information.

The data in the charts has been computed from actual flight tests with the sailplane in good and clean condition and using average piloting techniques.

5.2 Approved data

5.2.1 Airspeed indicator system calibration

IAS = indicated airspeed
CAS = calibrated airspeed

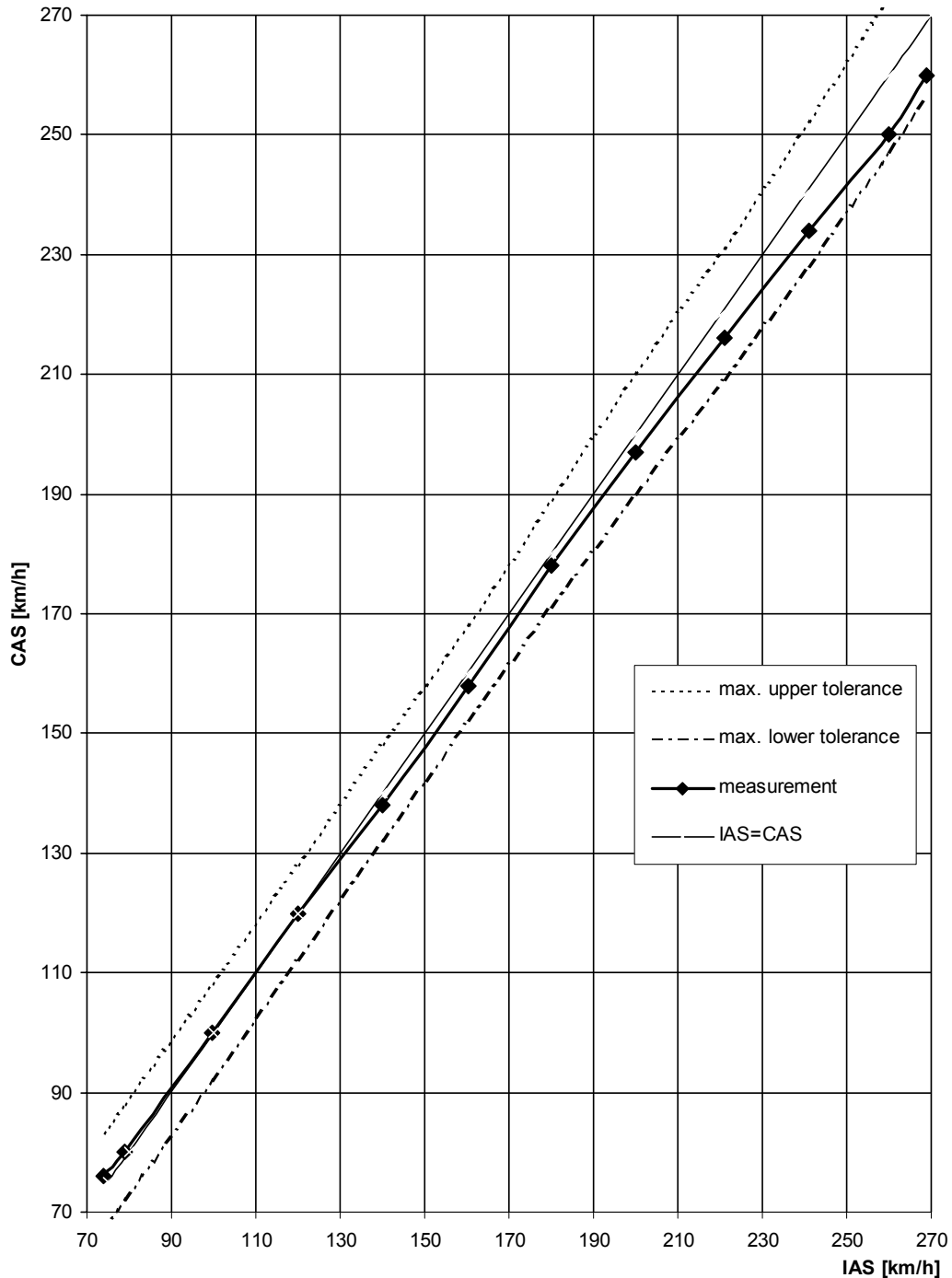

Caution: The airspeed indicator is to be connected to the static ports and pitot probe in the fuselage nose.

Flight manual DG-1000S

5.2.2 Stall speeds

The given speeds are the minimum achievable speeds during level flight in km/h and (kts.).

Airbrakes retracted 20m span

mass kg	470	500	550	600	650	700	750
mass lbs.	1036	1102	1213	1323	1433	1543	1653
W/S kg/m ²	26,8	28,5	31,4	34,2	37,1	39,9	42,8
W/S lbs./ft. ²	5.5	5.84	6.43	7.01	7.59	8.18	8.76
V km/h	62,9	64,9	68,0	71,1	74,0	76,8	79,5
V kts.	34	35	36.7	38.4	40	41.5	42.9

Airbrakes retracted 18m span

W/S kg/m ²	28,1	29,9	32,9	35,9	38,9	41,9	44,9
W/S lbs./ft. ²	5.76	6.12	6.43	7.35	7.96	8.57	9.18
V km/h	64,4	66,4	69,7	72,8	75,8	78,6	81,4
V kts.	34.8	35.9	37.6	39.3	40.9	42.4	44

Airbrakes extended 20m span

mass kg	470	500	550	600	650	700	750
V km/h	67,4	69,5	72,9	76,2	79,3	82,3	85,1
V kts.	36,4	37,5	39,4	41,1	42,8	44,4	46,0

Airbrakes extended 18m span

V km/h	69,0	71,2	74,7	78,0	81,2	84,2	87,2
V kts.	37,3	38,4	40,3	42,1	43,8	45,5	47,1

The loss of height for stall recovery is approximately 30 m (100 ft) if recovered immediately.

Flight manual DG-1000S

5.3 Additional Information

5.3.1 Demonstrated crosswind performance

The demonstrated crosswind velocity is 15 km/h (8 kts) according to the airworthiness requirements.

5.3.2 Gliding performance

Performance data with **20 m** span ($S = 17,53 \text{ m}^2$)

wing loading	kg/m ²	28	35	42
minimum sink	m/s	0,51	0,56	0,62
at	V [km/h]	79	88	98
best glide ratio	/	45,9	46,3	46,6
at	V [km/h]	93	104	120

Performance data with **18 m** span ($S = 16,72 \text{ m}^2$)

wing loading	kg/m ²	30	36	45
minimum sink	m/s	0,60	0,65	0,72
at	V [km/h]	84	90	100
best glide ratio	/	41,5	41,7	42
at	V [km/h]	100	110	123

A variation in speed by $\pm 10 \text{ km/h}$ (5 kts.) from the above will decrease the best glide angle by 0.5 glide points and increase the min. sink rate by 1 cm/sec. (2 ft/min).

The polar curves can be seen on the next page.

For optimum performance, the aircraft should be flown with a C.G. towards the rear of the allowable range. This especially improves thermalling performance. However the aircraft will be more pitch sensitive.

The wing fuselage joint, wing parting and the tailplane fin joint should be taped up and the aircraft thoroughly cleaned to obtain maximum performance.

The polars apply to a "clean" aircraft.

With dirty wings or flight in rain, the performance drops accordingly.

Flight manual DG-1000S

5.3.3 Flight polar with 20 m wing span

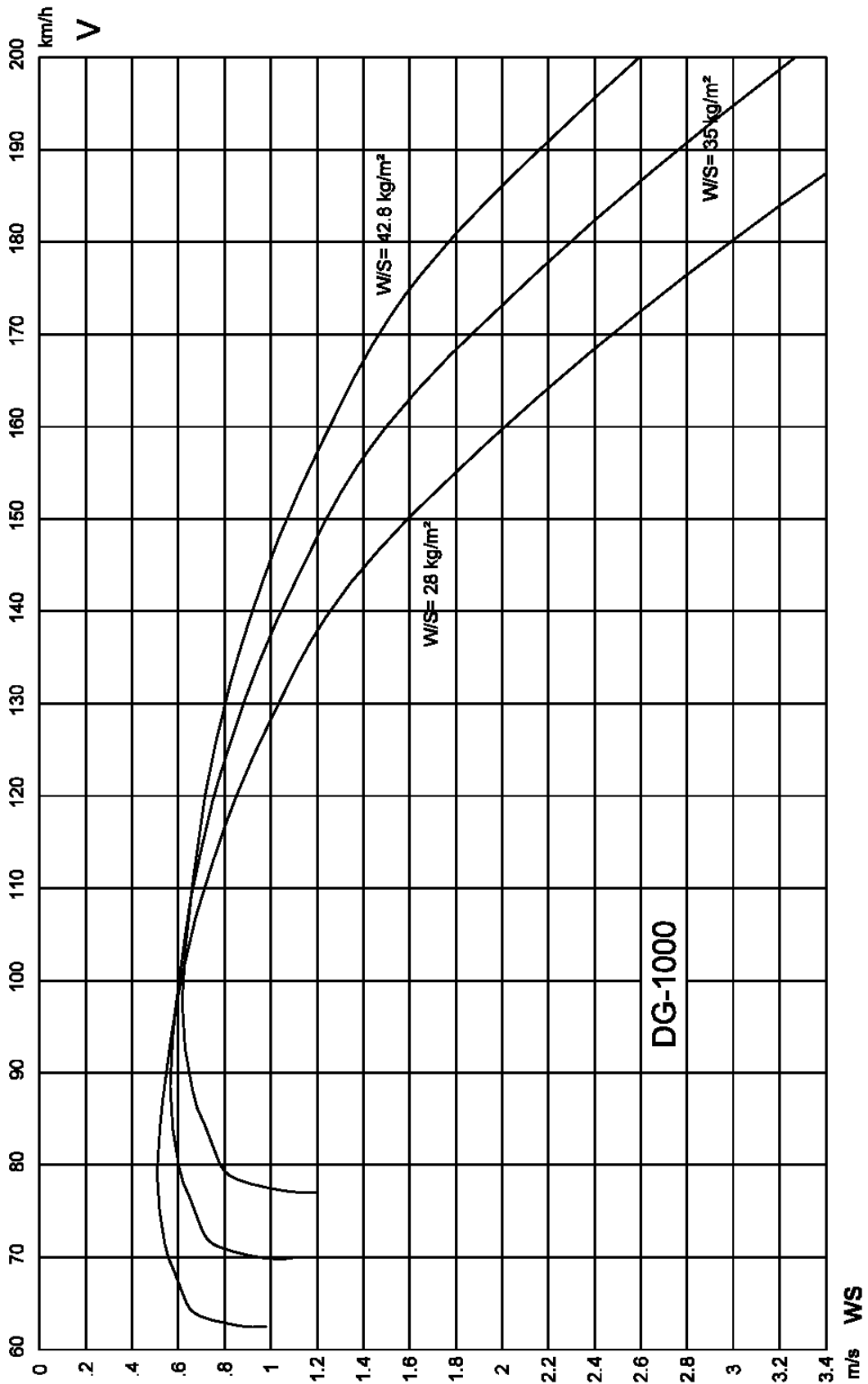

5.3.4 Flight polar with 18 m wing span

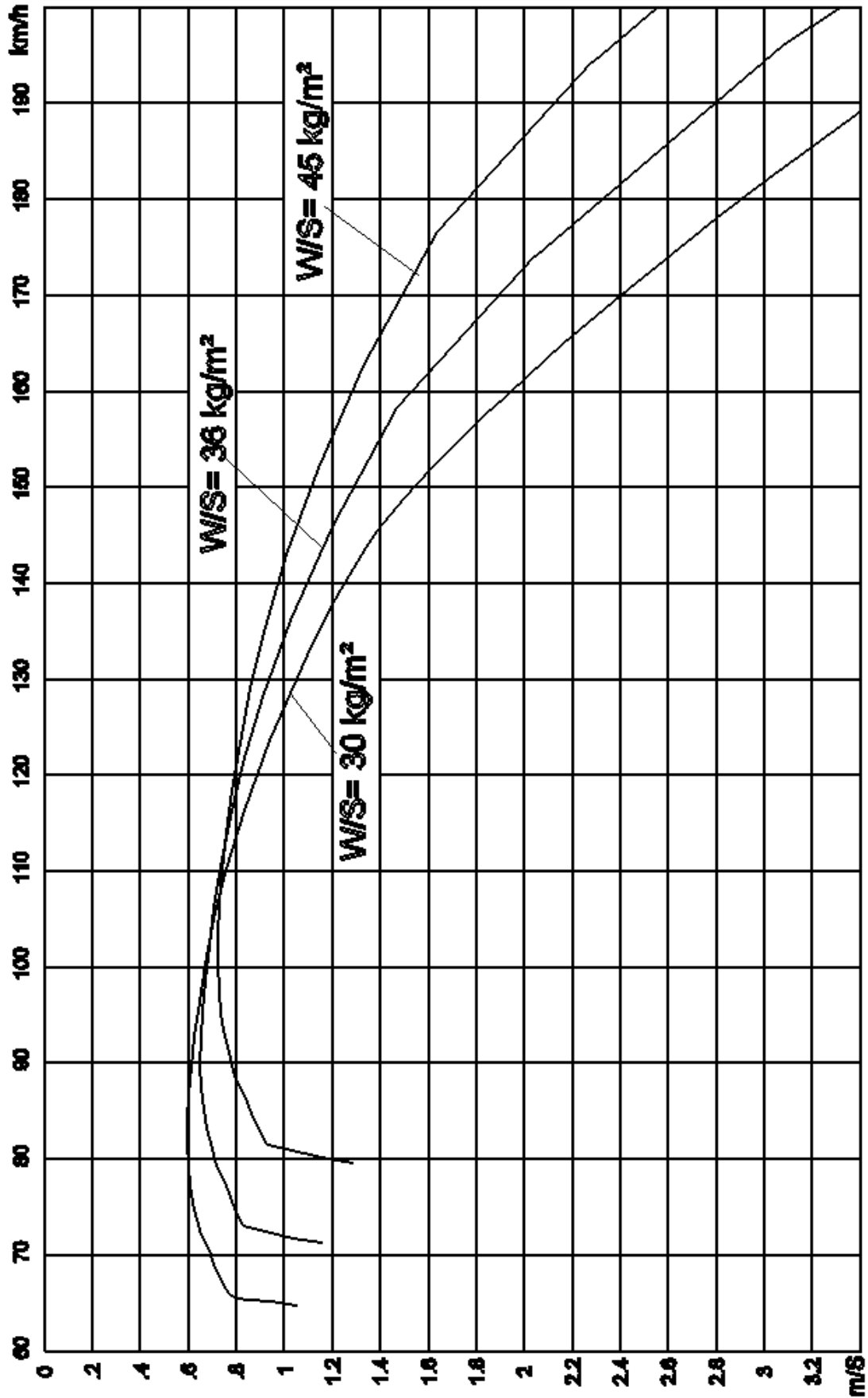

Flight manual DG-1000S

6 Mass (weight) and balance

	Page
6.1 Introduction.....	6.2
6.2 Weighing procedures	6.2
6.3 Weighing record.....	6.2
6.4 Basic empty mass and C.G.	6.2
6.5 Mass of all non-lifting parts (WNLP).....	6.3
6.6 Max. mass (weight).....	6.3
6.7 Useful loads	6.3
6.8 Loading chart	6.4
6.8.1 Cockpit load	6.4
6.8.2 Removable ballast for underweight pilots	6.4
6.8.3 Baggage.....	6.4
6.8.4 Battery in the fin	6.5
6.8.5 Waterballast in the wing tanks	6.5
6.8.6 Fin ballast tank	6.5
6.8.7 Ballast box in the fin	6.6
6.8.8 Weighing report (for section 6.3).....	6.7
6.8.9 Empty weight C.G. limits (for 6.4).....	6.8
6.8.10 DG-1000 ballast chart (for 6.8.5).....	6.9
6.9 C.G. calculation	6.10

Flight manual DG-1000S

6.1 Introduction

This section contains the payload range within which the sailplane may be safely operated.

A procedure for calculating the in-flight C.G. is also provided.

A comprehensive list of all equipment available for this sailplane is contained in the maintenance manual.

6.2 Weighing procedures

See maintenance manual DG-1000S.

Datum: Wing leading edge at the rootrib.

Reference line: aft fuselage centre line horizontal.

The weighing is to be executed with all tanks emptied, without ballast in the trim ballast boxes in the fin and in the cockpit (optional), but with fin battery Z110.

6.3 Weighing record

The result of each C.G. weighing is to be entered on page 6.7. If the min. cockpit load has changed this data is to be entered in the cockpit placard as well. When altering the equipment, the new data can be gathered by a C.G. calculation (see section 6.9).

The actual equipment list is enclosed in the maintenance manual.

6.4 Basic empty mass and C.G.

Actual data see page 6.7. With the empty weight C.G. and the cockpit loads in the limits of the diagram on page 6.8, the in-flight C.G. limits will not be exceeded.

Flight manual DG-1000S

6.5 Mass of all non-lifting parts (WNLP)

The max. mass of all non-lifting parts is 469 kg (1034 lbs.).

WNLP is to be determined as follows:

WNLP = WNLP empty + cockpit load (pilots, parachute, baggage, trim ballast, waterballast in the fin, removable items of equipment etc.).

WNLP empty = Total empty weight incl. permanently installed equipment minus weight of the wings.

6.6 Max. mass (weight)

Category A „Aerobatic“

Maximum take off weight:	630 kg	1389 lbs.
Maximum landing weight:	630 kg	1389 lbs.

Category „Utility“, retractable main wheel:
with waterballast:

Maximum take off weight:	750 kg	1653 lbs.
Maximum landing weight:	750 kg	1653 lbs.

without waterballast: Maximum take-off and landing mass = $W_{NLP} + W_{wings}$

W_{NLP} = Maximum mass of all non lifting parts (see above)

W_{wings} = actual mass of the wings

Category „Utility“, fixed main wheel:

Maximum take off weight:	630 kg	1389 lbs.
Maximum landing weight:	630 kg	1389 lbs.

6.7 Useful loads

Max. load **without** waterballast

= max. weight without waterballast - empty weight

Max. load **with** waterballast

= max. weight with waterballast - empty weight

The data is recorded on page 6.7.

Flight manual DG-1000S

6.8 Loading chart

6.8.1 Cockpit load

see weighing report section 6.8.8.

a) single seated:

max. load in the front seat 110 kg (242 lbs)

min. load in the front seat see placard in cockpit and weighing report

b) two-seated:

max. cockpit load is 210 kg (463 lbs.) with a max. of 105 kg (231 lbs.) in the front seat or 110 kg (242 lbs.) in the front seat and 90 kg (198 lbs.) in the rear seat.

min. cockpit load in the front seat is the min. cockpit load see a) minus 40% of the load in the rear seat.

c) With these loads, the C.G. range given under section 6.8.8 will be kept in the limits if the empty weight C.G. is in its limits.

With lower pilot weight necessary ballast must be added in the seat or in the optional ballast boxes see below. Ballast put on the seat (lead ballast cushion) must be fastened at the connections of the safety belts.

6.8.2 Removable ballast for underweight pilots

Option: Ballast boxes in the front cockpit for removable Ballast (trim weights), see section 7.15.1.

6.8.3 Baggage

max. 15 kg (33lbs)

Heavy pieces of baggage must be secured to the baggage compartment floor (screwing to the floor or with belts). The max. mass secured on one half of the floor (left and right of fuselage centre line) should not exceed 7,5 kg (16.5 lbs.). The added load in the fuselage must not exceed the max. load without waterballast (W.B.) see weighing report section 6.8.8.

Flight manual DG-1000S

6.8.4 Battery in the fin

Only the use of the factory supplied battery Z110 (mass 5.75 kg, 12.7 lbs.) is permitted.

Warning: Flying is only allowed with the battery in the fin as otherwise the forward C.G. limit may be exceeded.

Instead of the battery a suitable weight of 5,5 kg may be used.

6.8.5 Waterballast in the wing tanks (Option)

The tanks have a capacity of 80 l (21,2 US gallons) per wing

The permitted amount of waterballast is dependent on the empty weight and of the load in the fuselage and can be determined from the diagram “**Ballast chart**” section 6.8.10.

It is only allowed to fly with symmetric wing ballast!

6.8.6 Fin ballast tank (Option)

Water ballast in the fin tank should be used to compensate the forward move of C.G. due to the water ballast in the wings.

The amount of ballast in the fin is dependent on the amount of water in the wing tanks and to be determined from the following table.

waterballast in the	
wings	fin
kg	kg
20	0,6
40	1,3
60	2,1
80	2,9
100	3,8
120	4,6
140	5,4
160	6,2
/	/

waterballast in the	
wings	fin
lbs.	lbs.
40	1,2
80	2,7
120	4,2
160	5,9
200	7,5
240	9,2
280	10,8
320	12,4
350	13,5

Flight manual DG-1000S

6.8.7 Ballast box in the fin

Compensation of the C.G. shift due to the rear pilot:

The ballast box can accommodate max. 4 weights of 2,4 kg mass (heavy weight) and 2 weights of 1,2 kg mass (light weight), so the max. mass is 12 kg.

The number of weights can be determined by the following table:

Mass of rear pilot		Number of trim weights	Number of blinks of the lamp in the front instrument panel see section 4.2.4
kg	lbs.		
55	121	2 heavy + 1 light	5
65	143	3 heavy	6
75	165	3 heavy + 1 light	7
85	187	4 heavy	8
95	209	4 heavy + 1 light	9
105	231	4 heavy + 2 light	10

Warning: When flying solo the ballast box must be emptied!

Otherwise you will fly with a dangerous C.G. position.

If the ballast box is filled up, the min. cockpit load in the front seat is raised by 35 kg (77 lbs.).

The resulting value (min. cockpit load in front seat from weighing without ballast + 35 kg) must be entered in the table on page 6.7 as value XX and also on the placard at the indication lights for the fin tank on the front instrument panel.

When using the trim weights make sure not to exceed the max. weight of 750kg (1167 lbs.) Category „U” or 630kg (1653 lbs.) Category „A“ and Category „U“ with fixed undercarriage.

Trim-possibility for heavy pilots:

The ballast box may be used for this purpose too.

One trim weight of 1.2 kg raises the min. load in the front seat by 3.5 kg (7.7 lbs.).

One trim weight of 2.4 kg raises the min. load in the front seat by 7 kg (15.4 lbs.).

Example:

Min. cockpit load of the glider:	70 kg	permissible amount of trim weights
Mass of the front pilot:	84 kg	2 x 2.4 kg
Mass of the rear pilot:	65 kg	3 x 2.4 kg or 2 x 2,4 kg and 2 x 1,2 kg
Total amount of trim ballast:		12 kg

This means that the ballast box can be filled completely for this example.

Higher pilot masses can't be compensated.

Flight manual DG-1000S

6.8.8 Weighing report (for section 6.3)

Distances in mm, masses in kg -- 25.4 mm = 1 inch / 1 kg = 2.2046 lbs.

Date of weighing:						
Executed by:						
Date of equipment list:						
wing span	18m	20m				
Empty mass						
Empty mass C.G.						
Max. mass without W.B.						
Cat. U						
Cat. A	630	/				
Max. load without W.B.						
Cat. U						
Cat. A						
max. mass with WB						
max. useful load with W.B.						
min. cockpit load YY (kg)						
min. cockpit load XX (kg)						
max. load in both seats	210	210				
Inspector, signature, stamp						

YY= min. load in front seat for solo flying with fin ballast box empty.

XX= YY+35= min. load in front seat for solo flying with fin ballast box filled.

Weighing was executed with: battery in the fin Z110

tailwheel with: plastic hub

brass hub (see section 7.15.4)

Flight manual DG-1000S

6.8.9 Empty weight C.G. limits (for 6.4)

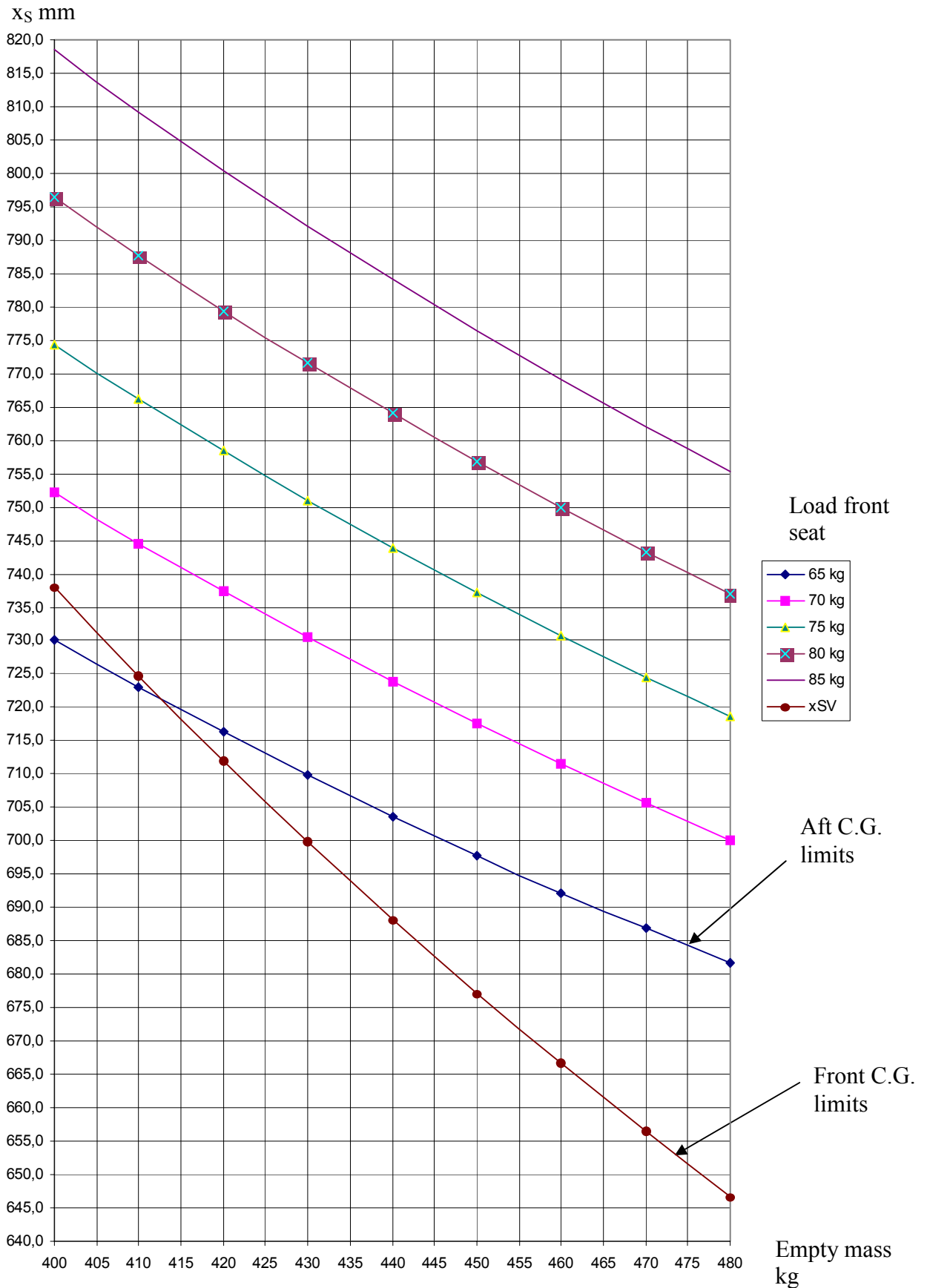

Flight manual DG-1000S

6.8.10 DG-1000 ballast chart (for 6.8.5)

To determine the max. allowable waterballast in the wing tanks for max. take off weight 750kg

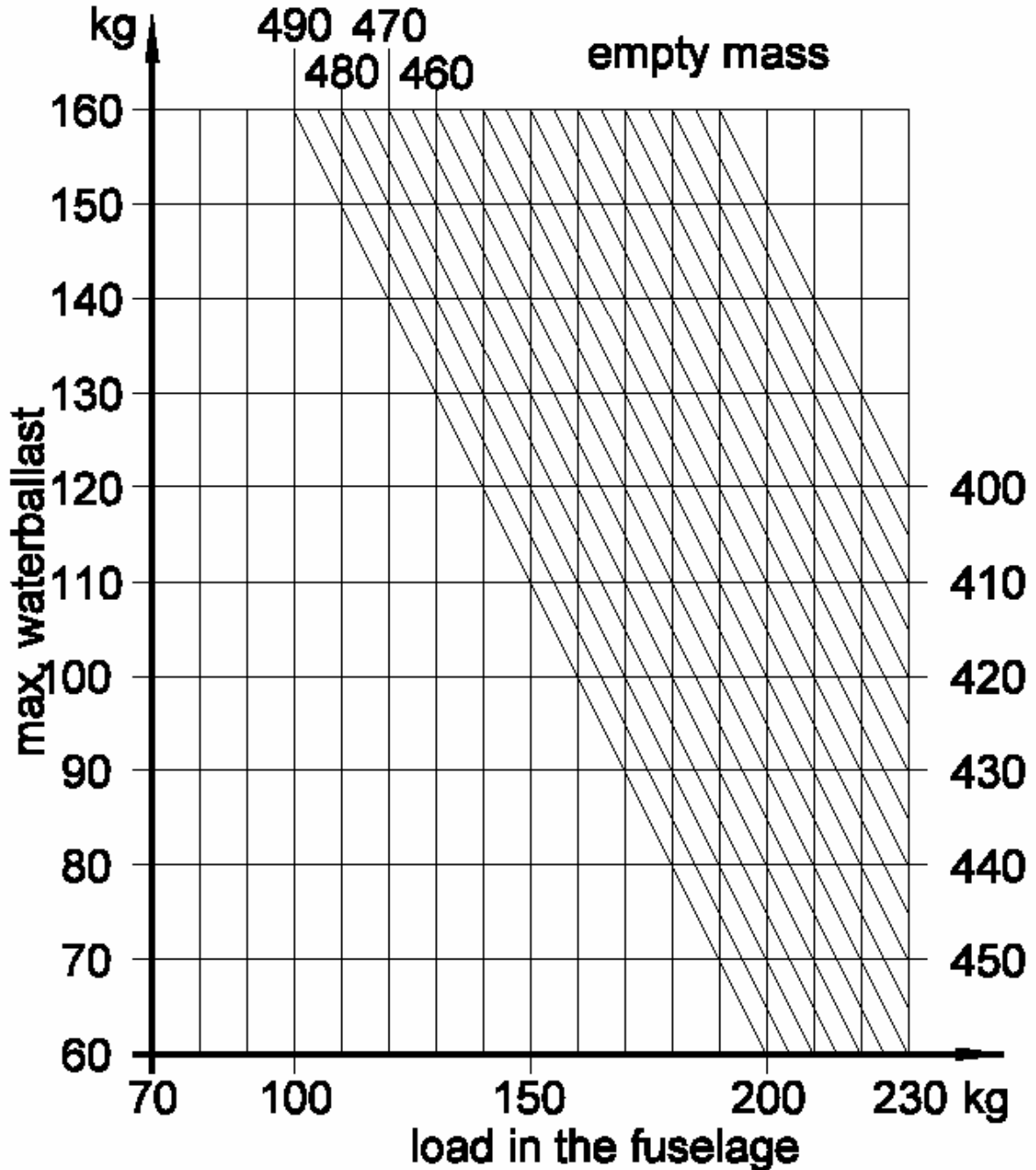

1 kg = 2.2046 lbs.

3.785 kg (l) = 1 US gal.

Flight manual DG-1000S

6.9 C.G. calculation

The actual C.G. can be determined as follows:

For each item, the moment mass x C.G. has to be determined and to be added up and divided by the total mass. See the following example:

1 kg = 2.2046 lbs. = .264 US gal. water 0.305 m = 1 ft

Item	mass [kg]	C.G. behind Datum [m]	Moment [m×kg]
Aircraft empty (with Battery in the fin)	430	0,740	318,20
Pilot front	75	- 1,350	- 101,25
Rear	85	- 0,280	- 23,80
Waterballast in the wings	140	0,206	28,84
Water in the fin tank	5,4	5,260	28,40
Ballast in box in the fin	9,6	5,400	51,84
Total:	745	X_S = 0,406	302,2

(X_S = Moment/Mass)

The limits of the in-flight C.G 0,190m - 0,440m should not be exceeded!

The most important C.G. positions (behind datum):

Pilot: The C.G. position is dependent on the pilots shape, mass and thickness of the parachute. The pilot C.G. position can be determined by executing a weight and balance measurement with glider empty and equipped with the pilot etc. see maintenance manual. Please note, that the distance a has to be measured with both configurations, as it may change due to deflection of the landing gear.

The pilot C.G. can be determined by the following equation:

$$X_P = (X_{SF} * M_F - X_{SE} * M_E) / M_P$$

M_F = flight mass X_{SF} = flight C.G M_P = pilot mass
M_E = empty mass X_{SE} = empty C.G.

Flight manual DG-1000S

If the actual pilot C.G. is not known, you have to take the values from the following table:

flight: v = near the forward C.G.
 h = near the aft C.G.

Pilot mass [kg]	Pilot C.G. lever [m]			
	Front cockpit		Rear cockpit	
	v	h	V	h
110	-1,388	-1,335	-0,317	-0,272
105	-1,390	-1,336	-0,318	-0,273
100	-1,391	-1,337	-0,319	-0,274
95	-1,392	-1,338	-0,320	-0,275
90	-1,393	-1,340	-0,321	-0,276
85	-1,395	-1,341	-0,323	-0,277
80	-1,396	-1,342	-0,324	-0,278
75	-1,397	-1,343	-0,325	-0,279
70	-1,399	-1,344	-0,326	-0,280
65	-1,400	-1,345	-0,328	-0,281
60	-1,401	-1,346	-0,329	-0,282
55	-1,402	-1,347	-0,330	-0,283

Further C.G. positions:

Baggage and battery in baggage compartment	0,270 m
Waterballast in the wings	0,206 m
Fin ballast tank (see section 6.8.6)	5,260 m
Ballast box in the fin (see section 6.8.7)	5,400 m
Instruments in front panel	-1,910 m
Instruments in rear panel	-0,740 m
removable ballast (Option, see section 7.15.1)	-1,960 m
Battery in fin (see section 6.8.4)	5,340 m
Tail wheel /see section 7.15.4)	5,305 m

Flight manual DG-1000S

7 Sailplane and systems description

	Page
7.1 Introduction.....	7.2
7.2 Airframe.....	7.2
7.3 Cockpit, cockpit controls and placards.....	7.3
7.4 Flight controls.....	7.7
7.5 Airbrakes.....	7.7
7.6 Landing gear.....	7.8
7.7 Tow hooks.....	7.8
7.8 Seats and safety harness.....	7.9
7.9 Baggage compartment.....	7.9
7.10 Waterballast system (Optional with 18m wingspan, standard with 20m wingspan).....	7.9
7.11 Ballast box in the fin.....	7.10
7.12 Electrical system.....	7.10
7.13 Pitot and static system.....	7.11
7.14 Canopies.....	7.11
7.15 Miscellaneous equipment (Options).....	7.11
7.15.1 Removable ballast for under weight pilots.....	7.11
7.15.2 Oxygen system.....	7.12
7.15.3 ELT Emergency Locator Transmitter.....	7.12
7.15.4 Heavy tailwheel.....	7.12
7.15.5 Battery in the baggage compartment with battery selector switch..	7.13

Flight manual DG-1000S

7.1 Introduction

This section provides description and operating of the sailplane and its systems.

M.M. = Maintenance manual

Refer to section 9 "Supplements" for details of optional systems and equipment.

7.2 Airframe

The DG-1000S is a two-place high performance sailplane, either with 18 m span or with 20 m span and permanently installed winglets

Construction

Wings	CFRP-foam-sandwich-shell with CFRP-roving spar caps
Ailerons	CFRP-foam-sandwich-shell
Rudder	GFRP-foam sandwich-shell
Horizontal stabilizer	GFRP-foam sandwich-shell with CFRP-roving spar caps
Elevator	GFRP-shell
Fuselage	GFRP-shell, fuselage boom sandwich-shell with Tubus core

Canopy

Two canopies hinged at the right hand fuselage side. Canopy transparencies made from Plexiglas GS 245 clear or green 2422 as option.

Tailplane

T-Tail with conventional stabilizer-elevator and spring trim.

Colour

Airframe: white
registration numbers: grey RAL 7001
or red RAL 3020
or blue RAL 5012
or green RAL 6001

7.3 Cockpit, cockpit controls and placards

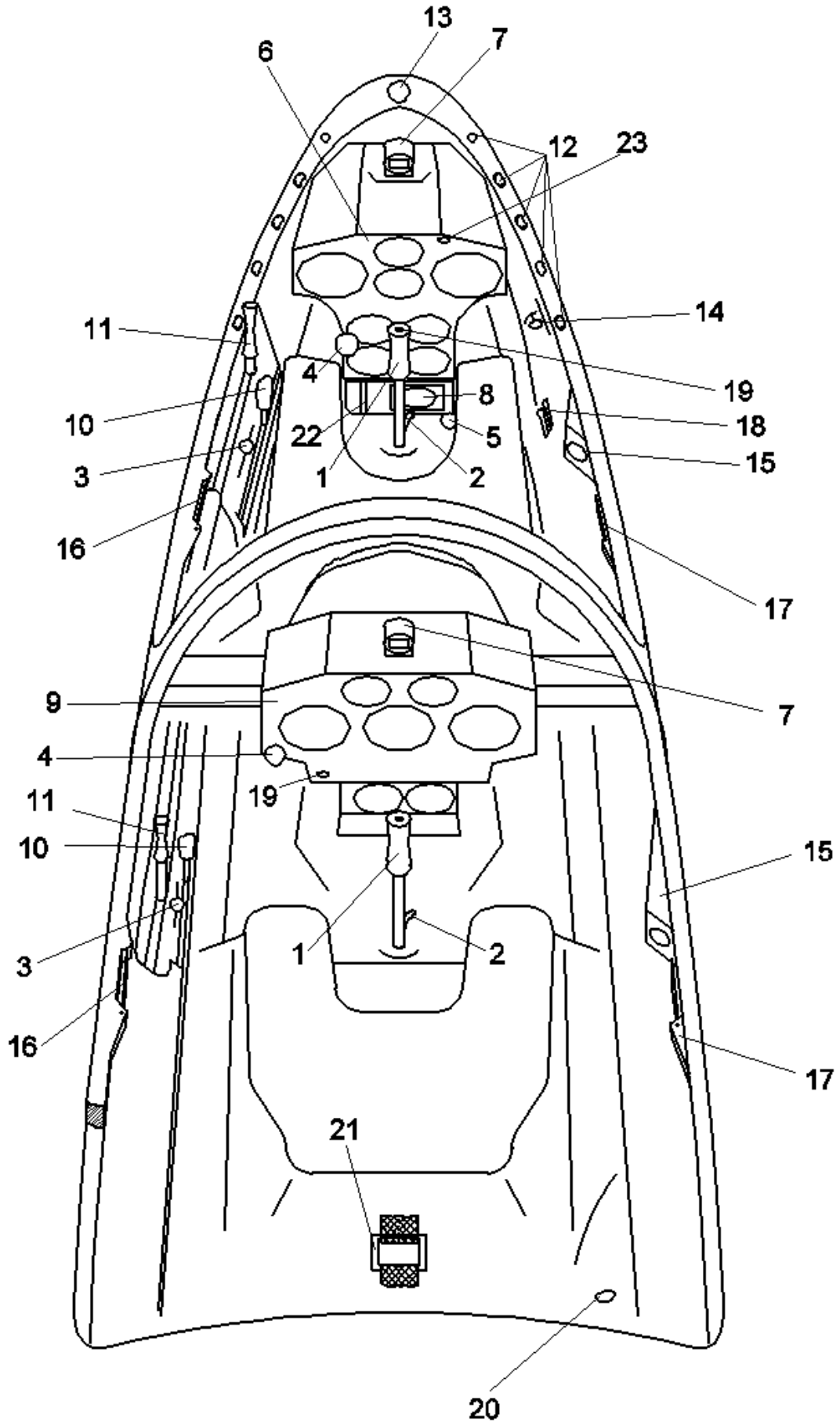

Flight manual DG-1000S

1) Control column

The rear control stick is removable. First open the snap shackle at the trim release lever to disengage the trim cable. Pull out the stick after unscrewing the cap nut.

2) Release lever for the trim mechanism - green

Operation see section 7.4 elevator control

3) Trim position indicator and trim preselection lever



4) Tow release knob - yellow



5) Rudder pedal adjustment knob – black (only in front cockpit)



By pulling on the knob, the locking pin will be disengaged and the rudder pedals can be pulled back towards the pilot or pushed forward away from the pilot.

6) Front instrument panel

After removing the side screws at the base 2 x M 6 and after removing the screws attaching the cover to the panel 6 x M 4, the cover can be removed towards the front. The panel remains in the aircraft.

7) Compass installation position

8) Radio installation position

9) Rear instrument panel

After removing the side screws attaching the panel to the cover (4 x M 4) the panel can be hinged backwards into the cockpit (take out the control stick first!).

Flight manual DG-1000S

- 10) Undercarriage retraction - extension handle - black



back = retracted, front = extended,

The undercarriage is locked in the extended position by an overcentre locking arrangement and an additional safety catch in the cockpit. The handle is to be turned towards the cockpit wall, so that the locking catch will engage.

In retracted position the landing gear is locked over centre.

With TN1000/13 executed, standard from ser. no. 10-133 on:

An additional landing gear positive locking device (notch and latch at the landing gear struts) secures the landing gear in the extended position.

An additional catch in the front upper area of the landing gear box secures the landing gear in retracted position.

- 11) Airbrake handle - blue

The wheel brake is operated at the end of the airbrake handle travel.



Optional parking brake combined with an airbrake securing device (Piggott-hook): Pull the airbrake handle back to actuate the wheelbrake and rotate the handle to the cockpit wall. A detent will engage in one of 4 notches to hold the system in this position.

In case the airbrakes mistakenly haven't been locked, a detent engages in one of several notches to avoid inadvertent deployment of the airbrakes. To open and to close the airbrakes the operating handle must be rotated into the cockpit so far that the detent passes the notches.

- 12) Constantly open de-misting air vents

- 13) Main air vent

- 14) Main air vent operating knob

pushed to front = closed

pulled = open



- 15) Swivel air vents

Flight manual DG-1000S

- 16) Canopy opening handle - white-red
 towards the nose = closed
 into cockpit = open
- 17) Canopy emergency release handle - red
 towards the nose = closed
 into cockpit = open

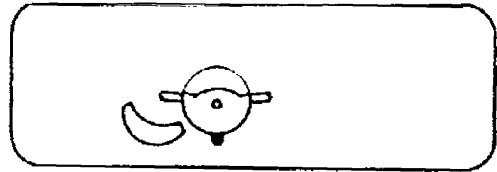
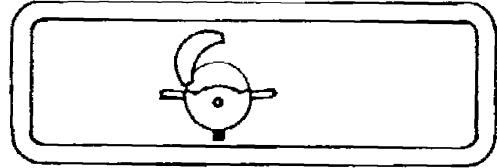

For emergency release also handle 16 has to be operated!

- 18) Water ballast dump handles - silver
 lever on top of the handles = fintank
 Rotate backward to dump. The wing waterballast can only be dumped after dumping the fin waterballast
- | | | |
|------------------|--|---|
| upper handle | = right wingtank |  |
| lower handle | = left wingtank | |
| forward | = valve closed | |
| into the cockpit | = valve open. The wing ballast can only be dumped after opening the fin tank | |

- 19) Push to talk button (Option)



- 20) 12 V socket for charging the batteries.

- 21) Adjustment strap for the rear seat shell (to be operated on the ground)

- 22) Outside-air temperature gauge (required with fin tank).

- 23) Control light for the trim ballast box in the fin:

The control light in the front instrument panel starts blinking after each transaction with the weights. By counting the amount of blinks, the amount of ballast can be

Trim-ballast box in the fin	
Min. load in the front seat	
<input type="text"/> kg	<input type="text"/> kg
box empty	box filled

determined. For a heavy weight 2 blinks appear and 1 blink for a light weight, this means 10 blinks if the box is filled up completely. After a pause of 2-3 seconds the blinking will be repeated etc.. The blinking can be stopped by pressing on the control light. Pressing again on the control light reactivates the blinking feature.

In addition with TN413/4 executed, standard from ser. no. 10-49 on:

A switch will be operated by the locking pin of the ballast box cover.

As long as the switch is not closed, the control light for the ballast box will blink with doubled speed without interruption. The blinking can't be switched off by pressing on the control light.

Flight manual DG-1000S

7.4 Flight controls

Rudder control

See diagram 2 M.M

Cable system with adjustable pedals in the front cockpit.

Elevator control

See diagram 1 M.M.

All pushrods slide in maintenance free nylon ball guides.

Automatic control hook up system. Spring trimmer with release lever at the control stick and control knob at the left cockpit wall. To trim, you have to operate the release lever at the control stick and place the control knob to the desired position.

Aileron control

See diagram 3 and 4 M.M.

Pushrods slide in maintenance free nylon ball guides.

Automatic control hook up system.

7.5 Airbrakes

See diagram 3 and 4 M.M.

Double storey Schempp-Hirth type airbrakes on the upper wing surface.

The wheel brake is operated by the airbrake system. Pushrods in the wings slide in maintenance free nylon ball guides. Automatic control hook up system.

Flight manual DG-1000S

7.6 Landing gear

The DG-1000S is available with 3 different versions of the undercarriage:

- A) Very high, spring mounted, retractable main wheel with hydraulic disc brake, see diagram 7 M.M, tail wheel.
- B) High spring mounted retractable main wheel with hydraulic disc brake, see diagram 8 M.M, tail and nose wheel
- C) Spring mounted, fixed main wheel with drum brake, see diagram 9 M.M., tail and nose wheel.

The main undercarriages versions B and C are interchangeable.

a) **Main wheel:**

retractable, assisted by a gas strut (locked in retracted position by an overcentre locking device) or non retractable.

Spring mounted with steel compression springs, fully sealed landing gear box,.

Tyre 380 x 150 6 PR, diameter 380 mm (15 in.),

Tyre pressure 2,5 bar (48 psi)

b) **Tail wheel:**

Tyre 200 x 50 2 PR

Diameter 200 mm (7,87in.)

Tyre pressure 4 bar (58 psi)

c) **Nose wheel (only version B) and C):**

Tyre 260 x 85

Diameter 260 mm (10,2 in)

Tyre pressure 2,5 bar (48 psi)

7.7 Tow hooks

See diagram 5 M.M.

Safety release "Europa G 88" for winch launch installed near the C.G.

"nose release E 85" installed in the fuselage nose for aerotow.

Both hooks are operated by the same handles.

7.8 Seats and safety harness

The front seat is constructed as an integral inner shell.

The rear seat is height adjustable. The adjustment is by means of a strap similar to the shoulder harness.

As safety harness only symmetric 4-point harnesses fixed at the given fixing points are allowed.

7.9 Baggage compartment

Max. load 15 kg (33 lbs.).

Heavy pieces of baggage must be secured to the floor.

7.10 Waterballast system

(Optional with 18m wingspan, standard with 20m wingspan)

See diagram 6 M.M.

The **wingtanks** are constructed as double wall bags with a capacity of 80 l per wing. The dump valves are mounted in the wings and the control is hooked up automatically when rigging the glider.

Fin ballast tank

Ballast to compensate the mass of the water ballast in the wings, max. 6,2 kg. This tank is an integral tank with a dump hose, an overflow and a ventilation line. The ventilation line ends in the fin trailing edge shear web, the dump hose and the overflow line are ending at the rear end of the fuselage besides the lower rudder mount.

Filling is via the dump hose. The dump valve is opened by a cable and closed by a steel tension spring.

Control handles

The handle for the fintank (wide plate) is above the wingtank handles, so that the wingtanks can only be emptied after opening the fintank.

Warning: It is prohibited to change this system!

The handle for the fintank will stay in the open position by an overcentre device. The upper handle is for the right and the lower handle for the left wingtank.

7.11 Ballast box in the fin

A box for ballast (trim-weights) is installed in the fin. It can be used to compensate the mass of the rear pilot and as a trim-possibility for heavy pilots. Max. ballast capacity: 12 kg.

Filling see section 4.2.4, determination of the permissible amount of ballast see section 6.8.7.

Indication of the amount of ballast inserted is via a control light in the front instrument panel see section 4.2.4 and section 7.3 item 23).

7.12 Electrical system

Battery in the fin.

For C.G. reasons the battery is installed in the fin. Only the use of the factory supplied battery Z110 (12 V, min. 12 Ah, mass 5.75 kg, 12.7 lbs.) is permitted. The battery fuse is installed at the battery, type: G fuse 250 V with indicator 5 x 25 medium slow / 4 A.

After inserting the connector plug in the fin the battery is connected to the electrical system of the glider. If you want to charge the battery inside the glider this can be done via the socket see section 7.3 item 20).

Warning: Use only automatic chargers designed to charge sealed lead acid batteries. To charge the battery to its full capacity a charger with 14.4 V max. charging voltage is necessary (normal automatic chargers charge only up to 13.8V). Such a charger is available from DG Flugzeugbau code no. Z 08.

For periodical recharging the “power independent “ unit is suitable. This unit is also available from DG Flugzeugbau.

All current - carrying wiring confirms to aeronautical specifications.

7.13 Pitot and static system

see diagram 8 M.M.

Pitot probe in fuselage nose, static ports a short distance behind fuselage nose. The airspeed indicator and the altimeter are to be connected to these ports and probe. Additional holder for a TE-probe or a Multiprobe in the fin is to operate variometer and flight computer systems. To preserve the sealings inside the holder, the end of the probe should be greased with e.g. Vaseline from time to time.

7.14 Canopies

To **jettison** the canopies in flight see section 3.2.

Removing a canopy:

Open the canopy, detach the restraining cable and if installed detach the gas strut from the front canopy. Then close the canopy and operate the red canopy emergency release handle (right) and the white-red canopy opening handle (left). Lift the canopy upwards.

Reinstalling a canopy:

Open emergency release and canopy locking levers. Place the canopy in vertical direction onto the fuselage. Close the emergency release. Open the canopy and snap in the retaining cable and the gas-strut (if installed).

Checking the canopy emergency release system:

- a) check with open front canopy if the gas-struts (if installed) can be disengaged from their ball fittings (from canopy and from fuselage). Grease the ball fittings.
- b) check with closed canopy if the emergency release handle can be operated and if the canopy can be removed easily, resp. if the canopy will be lifted by the gas-strut. Grease the locking pins.

7.15 Miscellaneous equipment (Options)

7.15.1 Removable ballast for under weight pilots

The ballast boxes (Option) at the right and left hand side of the instrument console underneath the carpets can accommodate 2 ballast weights of min 2.4 kg (5.3 lbs.) each. Each weight compensates a pilot mass of 3.2 kg (7 lbs.). So a max. of 12.8 kg (28 lbs.) missing pilot mass can be compensated.

The ballast weights are to be fixed in the box with a M8 knurled nut.

Note: The ballast weights used for the ballast box in the fin may be used for these ballast boxes too.

7.15.2 Oxygen system

a) Installation of the oxygen cylinders

Max. size of oxygen bottle is 7 l capacity with diameter 140 mm (5.5 in.)- If a bottle with smaller diameter is used, this bottle must be wrapped with plastic to come to the same diameter of 140 mm. The bottle must be fixed at its neck with a bracket Z 14 (available at DG-Flugzeugbau GmbH).

b) Installation of the oxygen equipment

To ensure a safe installation ask DG Flugzeugbau for an installation instruction. For the installation of the Dräger Höhenatmer E 20088 you will find an installation plan 5EP34 in the maintenance Manual.

7.15.3 ELT Emergency Locator Transmitter

To ensure a safe installation ask DG Flugzeugbau for an installation instruction. For the ELT ACK you will find an installation plan 5 EP50 in the maintenance manual.

Caution: Concerning 7.15.2 and 7.15.3

The installation has to be accomplished by the aircraft manufacturer or by an approved service station and to be inspected and entered in the aircraft log book by a licensed inspector.

7.15.4 Heavy tailwheel

Instead of the standard tailwheel with plastic hub S23 a tailwheel with brass hub S27/1 may be installed. The installation kit S27/4 is available at DG Flugzeugbau.

The difference in mass between both hubs is 3.1 kg (6.84 lbs.). With the brass hub the min. front cockpit load is increased by 8.5 kg (18.74 lbs.). This higher value must be entered in the cockpit data placards and on page 6.7. Even if the heavy tailwheel is installed only sometimes, the higher min. cockpit load must be entered.

7.15.5 Battery in the baggage compartment with battery selector switch

An additional battery Z01 12V 12AH may be installed in the baggage compartment. In this case a battery selector switch must be installed in the front instrument panel.

In the centre position of the switch both batteries are disconnected from the gliders electrical system.

In position I (left) the battery in the fin is connected to the electrical system.

In position II (right) the battery in the baggage compartment is connected to the electrical system.

Flight manual DG-1000S

8 Sailplane handling, care and maintenance

	Seite
8.1 Introduction.....	8.2
8.2 Inspection period, maintenance	8.2
8.3 Alterations or repairs.....	8.3
8.4 Tie Down, Parking.....	8.3
8.5 Transport	8.4
8.6 Towing on the ground.....	8.4
8.7 Cleaning and Care.....	8.5

Flight manual DG-1000S

8.1 Introduction

This section contains manufacturer's recommended procedures for proper ground handling and servicing of the sailplane. It also identifies certain inspection and maintenance requirements which must be followed if the sailplane is to retain that new-plane performance and dependability. It is wise to follow a planned schedule of lubrication and preventive maintenance based on climatic and flying conditions encountered.

8.2 Inspection period, maintenance

The "Instructions for continued airworthiness" (maintenance manual) for the DG-1000S have to be followed.

- A Before each rigging all the connecting pins and bushes should be cleaned and greased. This includes the control connectors.
- B The contact surfaces of the canopies to the fuselage are to be rubbed with colourless floor-polish (canopy and fuselage side) to reduce grating noise in flight. Polish at the beginning of the flight season and then every month.
- C Once a year all the bearings and hinges should be cleaned and greased. See the greasing programme of the maintenance manual.
Each year the control surface displacements, adjustments and general condition must be checked. (See the maintenance manual).

Flight manual DG-1000S

8.3 Alterations or repairs

It is essential that the responsible airworthiness authority be contacted prior to any alterations on the aeroplane, to ensure that the airworthiness of the sailplane is not impaired. It is prohibited to execute the alteration without the approval of the airworthiness authority. The manufacturer will not be liable for the alteration or for damages resulting from changes in the characteristics of the aircraft due to alteration. So it is strongly recommended to execute no alternatives which are not approved by the aircraft manufacturer.

External loads such as external camera installations are to be regarded as alterations! Repair instructions can be found in the DG-1000S repair manual. No repairs should be carried out without referring to the manual.

8.4 Tie Down, Parking

Use textile ropes or straps to tie down the wing tips. The fuselage should be tied down just ahead of the fin.

Water ballast can be left in the wings for a few days only, but not when there is the possibility of freezing! On sunny days the cockpit should be closed and covered.

Note: Longer parking with exposure to sun and humidity will cause premature ageing of the external surfaces of your sailplane.

Flight manual DG-1000S

8.5 Transport

It is recommended to carry this valuable sailplane in a factory approved closed trailer.

Approved fitting points:

Inner wing panels:

- Wing spar as close to wing rootrib as possible or a rootrib wing cradle.
- A wing cradle at the taper change.

Horizontal tailplane and outboard wing panel:

- Cradles as desired

Fuselage:

- A felt lined fibreglass nose cap which does not extend over the canopy, secured to floor.
- Fuselage dolly in front of the undercarriage
- Tail wheel-well in trailer floor. Secure fuselage with a belt in front of the fin or hold it down with the trailer top (soft foam in top).

All aircraft structures should not be subject to any unusual loads. With high temperatures that can occur inside trailers, these loads in time can warp any fibre reinforced plastic sailplane.

The trailer should be well ventilated so as to prevent moisture build up which could result in bubbles forming in the gelcoat. A solar powered ventilator is recommended.

8.6 Towing on the ground

- a) by towing from the nose hook using a rope with the standard double ring approved for the release
- b) by using a tow bar which is fixed at the tail dolly and a wing tip wheel.

The tow bar and wing tip wheel may be ordered through the DG Flugzeugbau factory.

8.7 Cleaning and Care

Exterior surfaces of the fibre-reinforced plastic parts

The surfaces are coated by a UP-gelcoat or Polyurethane paint (Option). This surface is protected by a hard wax coating which has been applied during production with a rotating disc ("Schwabbel" procedure). Do not remove the wax, because this would lead to shading, swelling and cracking of the surface. In general, the wax coat is very resistant. As soon as the wax coat is damaged or worn, a new coat has to be applied (see maintenance manual sect. 3.1). If you store your aircraft often outside, this may be necessary every half year!

Hints for care

- Wash the surface only with clean water using a sponge and chamois.
- The adhesive remains of tape may be removed with petroleum ether (pure petroleum spirit) which should be applied and removed immediately, otherwise this may lead to swelling of the gelcoat.
- More stubborn dirt which cannot be removed by washing may be cleaned off with silicone-free, wax containing car polishes (e.g. 1Z Extra, Meguiars in USA).
- Long-term dirt and shading can be removed by applying a new hard wax coat (see maintenance manual sect. 3.1).
- Never use alcohol, acetone, thinner etc.. Do not use detergents for washing!
- Protect the surface from intense sunlight.
- Protect the aircraft from water and moisture. See sections 8.4 and 8.5.
- Remove water that has entered and allow the aircraft to dry out.
- Never store your wet aircraft in a trailer.

Flight manual DG-1000S

Plexiglas canopy

- Use clean water and a chamois for cleaning.
- Stubborn dirt and small scratches can be removed by use of the "Schwabbel procedure" (see maintenance manual sect. 3.1).

Metal parts

- The pins and bushes for rigging the aircraft are not surface protected and must be covered with grease at all times.
- The other metal parts, especially the control stick and all handles should occasionally be preserved with metal polishes.

Flight manual DG-1000S

9 Supplements

Section		page
9.1	Introduction	9.2
9.2	List of inserted supplements	9.2
9.3	Electrically operated main landing gear	9.3 – 9.12
9.4	Special equipment for very small pilots	9.13

Flight manual DG-1000S

9.1 Introduction

This section contains the appropriate supplements necessary to safely and efficiently operate the sailplane when equipped with various optional systems and equipment not provided with the standard sailplane.

9.2 List of inserted supplements

Date of insertion	Document No.	Title of the inserted supplement
November 2008	Section 9.3	Electrically operated main landing gear TN1000/14
May 2010	Section 9.4	Special equipment for very small pilots TN1000/17

9.3 Electrically operated main landing gear

Introduction

In the following text the changes to those sections of the flight manual which are affected by the installation of the electrically operated main landing gear will be given

Section 1 General

1.4 Descriptive data

Subsection amended

With landing gear version A) the main landing gear may be operated electrically as an option, Version D).

D) Very high, spring mounted, electrically operated retractable main landing gear, wheel with hydraulic disc brake, tail wheel

With this version there are no handles and control rods for manual operation of the landing gear like Version A.

A landing gear warning device is integrated into the system.

Both cockpits are equipped with all controls and control lights

A manually operated emergency extension system is provided.

Technical data:

Extension and retraction time (electrically operated): approx. 7seconds

Extension time emergency operation: approx. 2 seconds

Flight manual DG-1000S

Section 2 Limitations

subsections amended

2.2 Airspeed

Note: VLO is not changed compared to the manually operated main landing gears

	Speed	IAS km/h (kts.)	Remarks
VLO	Maximum landing gear operating speed	185 (100)	Do not extend or retract the landing gear above this speed.
VLE	Never exceed speed in case the landing gear is not locked	150 (81)	Do not exceed this speed in case the landing gear is not locked, see emergency procedures sect. 3.20

Warning: If the landing gear is operated at speeds higher than VLO and if gusts generate accelerations higher than 4 g the landing gear may be damaged.

2.9 Approved manoeuvres

No aerobatic manoeuvres are allowed during extension and retraction of the landing gear and in case you fly with the landing gear is unlocked (see emergency procedures sect. 3.20).

2.10 Manoeuvring load factors

	max. speed	g-load
operating the landing gear	VLO	+4 -2,65
in case the landing gear is not locked	VLE	+4 -2,65

2.17 Limitation placards

Below the controls and control lights for the electrically operated landing gear see sect. 7.3:

LG ext.-retr. up to 185 km/h 100 kts.

Section 3 Emergency procedures

new subsection

3.19 Emergency extension of the electrically operated main landing gear

If extending the landing gear via the electrical system is not possible, the landing gear may be extended manually. The extension force is produced by a gas strut. For emergency extension pull on one of the 2 black-red emergency extension handles (located at the left hand fuselage wall, one in each cockpit), pull the handle until the landing gear is fully extended. The travel is about 15 mm (.6 in.), the extension time about 2 seconds. During extension the centre (red) LED is shining. When the landing gear is fully extended the lower green LED also starts shining.

Warning: Don't let the handle go before the green LED starts shining. If you don't pull for long enough the landing gear will rest in a position not locked over centre and will be destroyed at touch down.

Caution: If you execute the emergency extension at high airspeed it may take a longer time until the landing gear is fully extended. You should shorten the time by reducing the airspeed.

Caution: If emergency extension was necessary check the system to detect the failure and repair the system.

Resetting the system for normal operation see section 4.5.12.3.

3.20 Incompletely retracted electrically operated main landing gear

If the landing gear is not locked the centre (red LED) starts blinking approx. 22 seconds after the start of the retraction.

In this condition the retraction mechanism may be damaged with g-loads exceeding 4 g.

Instruction 1: Extend and retract the landing gear again.

Instruction 2: If instruction 1 was not successful extend the landing gear and land as soon as possible to fix the problem. For the remainder of the flight, don't fly faster than 150 km/h (81 kts.) and avoid abrupt manoeuvres.

Section 4 Normal procedures

4.2 Rigging and derigging

new subsection

4.2.8 Extension and retraction of the electrically operated main landing gear

Extension see 4.5.12.1 normal procedures

Warning: The main landing gear can only take up the weight of the glider when fully extended and locked. Therefore it is essential that during extension of the landing gear no load is applied to the main wheel. Lift the trailer ramp high enough. If there is a risk that the ramp may come down while the landing gear is extending secure the ramp, e.g. with blocks.

If such a case happens nevertheless switch the landing gear to retraction. To accomplish this you must switch up and hold the toggle switch and press the press button simultaneously 3 times within 2 seconds.

Warning: If you operate the retraction or extension the landing gear will travel to the up or down stop. So make sure that there are no obstacles which may be caught by the landing gear to prevent damage or injuries.

You can stop the travelling by switching the toggle switch in the reverse direction and pressing the press button simultaneously

4.5 Normal procedures

new subsection

4.5.12 Electrically operated main landing gear

4.5.12.1 Extension and retraction in flight

Retraction: For retraction switch and hold the toggle switch up and press the press button twice within 2 seconds. With each press on the button a signal will sound see section 4.5.16. The landing gear will retract automatically. You may let go of the switches. During retraction the centre (red) LED will shine and the upper green LED will blink. As soon as the landing gear is retracted and locked only the upper green LED will shine.

Warning: If the upper green LED doesn't start to shine and the red LED instead starts blinking refer to section 3.20 emergency procedures.

Extension: For extension switch the toggle switch down and let go.. The landing gear will be extended and locked.

During extension the centre (red) LED will shine and the lower green LED will blink. As soon as the landing gear is extended and locked only the lower green LED will shine.

Note: In case of high acceleration during extension or retraction an over current cut off system will switch off the spindle drive to protect the system. As soon as the g-loads decrease, the landing gear will continue to travel.

Note: To save electrical power during flight the upper green LED will stop shining after approx. 5 minutes, landing gear retracted and locked.

4.5.11.2 Extending the landing gear via the emergency extension system.

The emergency extension system is also designed to be operated for in flight training purposes. Operation see section 3.19.

Resetting the system for normal operation should be executed after landing, for procedure see section 4.5.12.3.

Caution: It is strongly recommended to train the emergency extension in flight.

Note: Resetting the system for normal operation is also possible in flight.

However, this is only permissible if there are 2 pilots on board, one pilot flying the glider and the other resetting the system.

Then you may retract the landing gear again according to section 4.5.12.1. to continue the flight.

4.5.12.3 Resetting the emergency extension system for normal operation

After an emergency extension the system must be reset for normal operation. To accomplish this you must pull one of the 2 emergency extension handles and simultaneously switch the toggle switch down. The centre (red) and the lower green LED will shine.

Switch and handle must be operated until the centre LED stops shining and only the lower green LED continues shining. The spindle drive will then stop operating, then let go handle and switch

Thereafter you may retract the landing gear again according to section 4.5.12.1.

4.5.12.4 Part extension and retraction for inspection and servicing

The retraction may be stopped by switching the toggle switch down,

The extension may be stopped by switching the toggle switch up and pressing simultaneously the press button.

Only the red LED will shine.

For any service work switch off the main switch!

With the procedures described in section 4.5.12.1 you may retract or extend the landing gear again.

4.5.12.5 Precautionary measures against retracting the landing gear while on the ground

If the glider is resting on the main landing gear the landing gear should not be retracted, as retraction will result in damage of the landing gear. To minimise the risk of such operating error the following safety features have been incorporated:

1. If the toggle switch is switched up, nothing will happen.
2. If the toggle switch is switched up and the press button is pressed 1 time a warning tone will sound, otherwise, nothing will happen.
3. Only if the toggle switch is switched up and the press button is pressed 2 times within 2 seconds the landing gear will be retracted.

Caution: If you leave the DG-1000 unattended switch off the main switch to prevent any operating error.

Section 7 Sailplane and system description

7.3 Cockpit, cockpit controls and placards

Subsection amended

Controls and control lights for the electrically operated landing gear in front and rear instrument panel (upper left hand side):

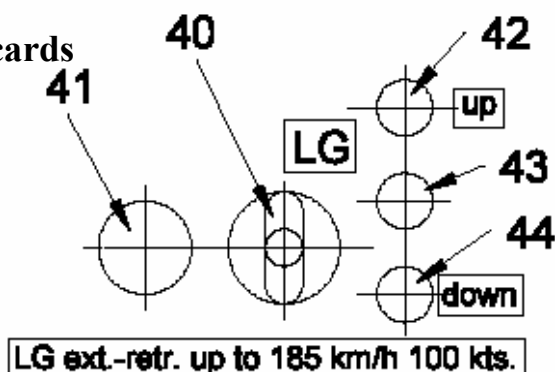

- 40) Toggle switch for extension and retraction of the electrically operated main landing gear
up retracted and locked
down extended and locked over centre
- 41) Press button for retraction of the electrically operated main landing gear
 For retraction switch and hold the toggle switch up and press the press button 2 times within 2 seconds.

42) – 44) control lights (LED's) for the electrically operated main landing gear:

Condition	control light indication
Normal operation	
LG retracted and locked	42) upper green shines
LG extended and locked	44) lower green shines
LG retracting	43) red shines, 42) upper green blinking
LG extending	43) red shines, 44) lower green blinking
LG stopped in intermediate position	43) red shines
Emergency operation	
LG extends	43) red shines
LG extended and locked	44) lower green shines, 43) red shines
System resetting	44) lower green shines, 43) red shines
Failure messages	
Time overflow: Signal appears if within 22 seconds after start of the travelling no limit switch activates	43) red blinking + upper or lower green blinking according to travel direction
One limit switch defective	all LED's blinking

Note: To save electrical power during flight the upper green LED will stop shining after approx. 5 minutes if the landing gear is retracted and locked.

Flight manual DG-1000S

45) Landing gear emergency extension handles – black-red
The handles are located at the left hand fuselage wall, one in each cockpit at the positions of the handles for the manually operated landing gears, item 10).

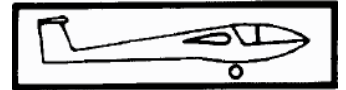

For emergency extension pull on one of the 2 red emergency extension handles, pull the handle until the landing gear is fully extended.

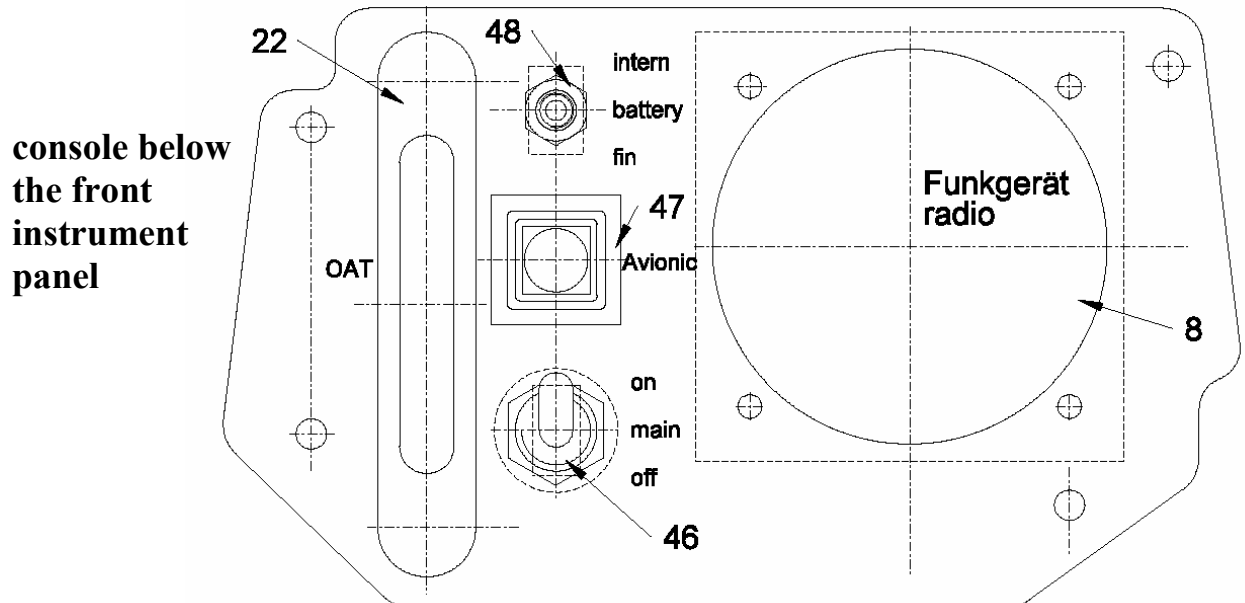

46) Main switch for the entire electrical system
up= on

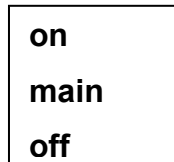

down= off

Note: If you don't operate the DG-1000, switch off the main switch. Otherwise the landing gear control unit will draw a small current and will empty the battery with time.

47) Circuit breaker for the instruments 4A



48) Selector switch for instrument power supply
up= battery in baggage compartment

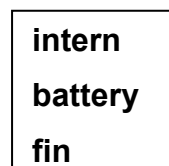

down= battery in the fin

Note: 26) Control light for the trim ballast box in the fin may not be installed at the position shown in the sketch on page 7.3 but at another suitable place in the front instrument panel.

7.6 Landing gear

Subsection amended

D) Very high, spring mounted, electrically operated retractable main landing gear, wheel with hydraulic disc brake, see diagrams 20 and 21 M.M, tail wheel
With this version there are no handles and control rods for manual operation of the landing gear like Version A.

In the normal operating mode the landing gear will be retracted and extended by an electrical spindle drive.

A control unit which is installed in the rear instrument tower controls all electrical functions and the control lights.

A landing gear warning device is integrated into the system.

Both cockpits are equipped with all controls and control lights

The landing gear will be locked in the extended position by over centre locking of the drag struts.

The landing gear will be locked in the retracted position by 2 latches.

The system is equipped with a safety circuit against retraction of the landing gear on the ground see section 4.5.12.5.

The system is equipped with an over current cut off which stops the extension or retraction if high accelerations occur to protect the drive against damage. As soon as the g-loads lower, the landing gear will continue to travel.

Emergency operation: If the electrical system is damaged or no battery power is available, the landing gear may be extended manually. The handles are located at the left hand fuselage wall, one in each cockpit at the positions of the handles for the manually operated landing gears).

Pulling on one of the 2 red emergency extension handles will open the valve of a lockable gas strut. The gas strut will push the spindle drive forward on a linear guide to extend and lock the landing gear.

Technical data:

Extension and retraction time (electrically operated): approx. 7seconds

Extension time emergency operation: approx. 2s

Power: 12V, max. 10 A

Flight manual DG-1000S

7.12 Electrical system

Subsection amended

Electrical system with electrically operated landing gear

Wiring see wiring plans 10E3 and 10E4 enclosed to the maintenance manual.

Batteries: To operate the electrically operated landing gear a battery Z01/2 must be installed in the baggage compartment. This battery must be equipped with a fuse G 250V 5x20 / 16A.

The battery in the fin Z110 (with fuse 4A) supplies power only to the instruments. The instruments may be switched by a selector switch in the front instrument panel to the battery in the baggage compartment.

Fuses and circuit breakers:

The electrically operated landing gear is protected by an automatically reset fuse in the landing gear control unit.

The wiring between battery and control unit is protected by the fuse at the battery.

The instruments are protected by a 4 A circuit breaker in the console below the front instrument panel.

Landing gear warning:

A landing gear warning device is integrated into the system. Warning is by a buzzer.

9.4 Special equipment for very small pilots (TN1000/17)

To facilitate the operation of the glider by very small pilots 3 different items have been developed, which may be used separately or together.

9.4.1 Removable seat back for the front seat

- a) Installation of the seat back: Install the seat back with 2 screws M6x16 DIN965 4.8 BIC with cup washers 15 x M6 MS NI NR4157 to the threads which have been installed according to working instruction No. 1 for TN1000/17.
- b) The seat back may be adjusted further to the front by part Z198. Fix the part to the Velcro straps installed at the rear of the seat back.
- c) DG-1000 from ser. no. 10-19 on: Remove the headrest 8R80/2 from the holder on the rear instrument panel cover (fixed with Velcro) and fix to the seat back. When removing the seat back reinstall the head cushion at the holder.
- d) DG-1000 up to ser. no. 10-18: Remove the head rest from the seat (screwed connection) and install a head cushion 8R80/2 to the Velcro straps installed at the front of the seat back.
When removing the seat back reinstall the headrest.

9.4.2 Airbrake-pushrod with additional handle in front cockpit

For pilots with arms too short to lock the airbrakes an airbrake-pushrod with additional handle part 5St69/2 may be instead in the front cockpit according to working instruction No. 2 for TN1000/17 instead of part 5St69.

This part may remain in the glider for normal operation.

9.4.3 Rudder pedal plates for rear cockpit Z197

Pilots with very short legs may clip rudder pedal plates part no. Z197 on to the rudder pedals. Plates may be installed and removed as often as desired.